

UnserHaus
Andheri: Arena House, 2nd Floor, Main Building, Plot No. 103,
Road No. 12, MIDC, Andheri, Mumbai - 400 093
Worli: 9th floor, Avantha Building (CG House), Dr. Annie Besant
Road, Century Bazar, Worli, Mumbai - 400030
www.bosch-home.in



BSH Household Appliances reserves the right to change specifications without notice in the interest of technological progress. While every effort has been made to ensure that all specifications and descriptions are correct at the time of going to press, this brochure should not be regarded as an infallible guide for a particular product. Due to variation in the reproduction process, colours of products may vary slightly from those depicted. We recommend a visit to a Bosch dealer to confirm that specifications and colours are to your own satisfaction. All rights reserved. No part of this publication may be reproduced in any form by any means without the permission of BSH Household Appliances Manufacturing Pvt. Ltd. (E.&O.E).

*Please note that this service is only available in English and for the appliances installed in cities - Mumbai, Delhi NCR, Bangalore, Kolkata, Hyderabad, Chennai, Ahmedabad, Pune and Jaipur. For further information please check: www.home-Connect.co.in or contact BSH Household Appliances Mfg. Pvt. Ltd. @ service.in@bosch-home.com

 **1-800-266-1880** (Customer care)
Monday-Saturday 8.00 am to 8.00 pm

 www.facebook.com/BoschHomeIn

 www.youtube.com/BoschHomeIn

 www.instagram.com/BoschHomeIn

 www.twitter.com/BoschHomeIn

Designed for quality. Invented for life.



**EUROPE'S
BRAND NO.1***

*For major domestic appliances.
Source: Euromonitor, volume sales, 2020.





“I would rather lose money
than trust.”

Robert Bosch

Building a future
full of convenience
and excellence.

Ever since founded by Robert Bosch in 1886, Bosch has always kept its philosophy of building trust of the people at the forefront. Built with the most advanced German technology, every appliance is perfectly designed to deliver world class quality performance. Taking this ideology forward in today's modern 21st century world and integrating it with the latest smart technology, Bosch introduces its Premium range of Home Appliances. Crafted for the digital generation with Home Connect features, control all your appliances with a single touch on your smartphone and explore the undiscovered joy of convenience.

Bosch – a brand you can trust.

Europe's No. 1 home appliance brand: Following in Robert Bosch's footsteps we've been pushing ourselves to deliver exceptional customer service. And we've successfully done this, for over 130 years. Our goal – to provide superior quality products with highly skilled resources. Everything from our product design to our relationship management is engineered around you. That's what makes us the No. 1 home appliance brand in Europe.

Quality: Our top-of-the-class German engineering in home appliances, allows us to manufacture quality products that are easy to use and deliver perfect results.

Design: Bosch is the No. 1 brand in design, with over 200 design awards over the past five years. Our quest for technical perfection, quality and simple operation is reflected in each design, so we can improve the quality of life for our users.

Convenience: Thoughtful engineering, like our Bosch sensor technology, helps you get the perfect cooking results every time. The FlameSelect® gas cooktop, lets you fine-tune the power levels and our self-cleaning functions save you the trouble of cleaning up after.

Performance: With features like Bosch Assist and advanced sensor technology found in PerfectBake™ and PerfectRoast™, our Bosch Series 8 ovens and compact appliances can modify the cooking process from start to finish, for that perfect bake or roast.

Sustainability: Our products focus on energy and water efficiency while achieving top performance. This helps minimize their impact on the environment.

Energy Efficient: All Bosch appliances are extremely energy efficient and many boast A+ energy efficiency ratings, as a result of our ground-breaking technologies.

Awards





A universal remote for all your Bosch Home Appliances, on your phone.

The Home Connect* app acts like a smart multi-tasking remote for all your Bosch appliances because it not only connects you to them but also single-handedly helps you manage and control their performance from your phone.

Key Innovations

Remote monitoring and control: Save the time and trouble of physically controlling your appliance by monitoring its performance and activating functions from your phone without being at home. You can preheat the oven, set the fridge's cooling, and even the wash cycle for the machine all through the app.

Ecosystem Partners: Easily pair and control your Bosch Home Connect appliances with multiple ecosystem partners such as Alexa, Google assistant, smart bulbs, etc. Organize your day to day life with Home Connect & it's partners.

Energy Management: The integrated Photovoltaic system provides you with smart, energy conservative usage solutions.

Security: We have gone more than that extra mile to give you a seamless, secure experience. Our Home Connect feature uses the same protocol as online banking, the app has a TUV Trust App Certification and all our Home Connect appliances are Wi-Fi certified by the Wi-Fi Alliance.

Push Notifications: Receive updates on your phone when your appliances complete tasks.



2-in-1 Cooktop with Integrated Ventilation



A combo of an induction hob and chimney like no other.

Integrated ventilation module of hobs which absorbs steam and deodorizes your kitchen.



Key Innovations

Specific features vary by model



Combi Zone: Reduce the fog of cooking smells from your kitchen, with a venting hob which removes it from the source. For more flexibility, you can combine two cook zones, one for roasting and the other to accommodate large pans.



PerfectCook: It's all about cooking as per the temperature of your pan rather than the power level of the hob. From defrosting, warming up, deep frying food to bringing your pasta to a perfect boil, you can do it all with the PerfectCook sensor. This smart sensor gives you more control when you cook. This feature requires the additional purchase of a cooking sensor to operate.



PerfectFry: May your meals never be overcooked or undercooked ever again. May they be just the way you like it, well-cooked. The FryingSensor ensures just that, by measuring the temperature in the pan and maintaining it, low and gentle heat for reducing sauces and high heat for frying steak. It has up to 5 automatic settings to heat the pan accurately.



DirectSelect: A simple control panel for selecting the desired cooking zone, adjusting the power and many more features.



Home Connect: Turn your appliance on and off from anywhere, with the Easy Monitoring feature on your phone. Set different timers for cooking zones or independent zones. Try the egg timer and count-up timer through the Remote Control feature. Keep your kids safe by activating or deactivating child lock via Safe & Sound feature on the app. Explore the World of Recipes with ingredients and preparation steps that can be transferred to your cooktop through Home Connect. Once the cooking zone is switched on, the ventilation module automatically absorbs unpleasant odours with the AutoOn function.



PVQ811F15E
Serie | 6
80 cm Induction Cooktop
with Integrated Ventilation System

Key highlights:

- **Extraction Rate:** 622 m³/h
- **Noise levels (min/max)** 42 dB / 69 dB
- Induction cooktop with fully integrated high-performance downdraft extractor
- **Powerful drainage system** for spillages that exceed 200 ml of liquids
- High-performance, low-noise blower with energy-efficient **BLDC technology**
- **DirectSelect** helps in selection of the desired cooking zone, power and additional functions
- 2 combinable zones '**CombiZone**' for large pans
- **QuickStart** function detects where you have placed the pot
- **ReStart** function stores your control settings

Convenience:

- 4 Induction cooking zones
- Automatic pan recognition sensor
- Dual function timer with automatic switch-off
- AutoOn Ventilation for fully-automatic extraction functionality
- Electronic DirectSelect premium touch-control

Safety:

- Automatic safety shut off, Control panel lock function
- Child lock
- 2-stage residual heat indicators
- Wipe protection

Cleaning:

- Dishwasher safe 12 layer stainless steel grease filters
- Easy to Clean as automatic pan recognition only heats up the base of the pan and not the rest of the zone

Technical :

- **Power levels:** 9 + 1 Intensive
- Total connected load 6.9kW
- Metal grease filters
- Nominal voltage (V) 220-240
- Maximum power output (W) 7400
- Electrical cable length (cm): 110
- 170 Power watt motor
- Variable 17-stage power settings for each zone

Dimensions:

- Appliance Dimension (HxWxD): 223 x 802 x 522 mm
- Cutout Dimension (HxWxD): 223 x 750 x 490 - 500 mm

Optional Accessories :

- HEZ390230: System pan diameter 21cm
- HEZ9CF260: System pan diameter 26cm
- HEZ9LP160: Induction compatible Pot 1.7 Lts
- HEZ9LP200: Induction compatible Pot 3.6 Lts
- HEZ9SE030: Set of 2 pots and 1 pan
- HEZ9VDSB1: 90° flat duct bend horizontal
- HEZ9VDSB2: 90° flat duct bend vertical
- HEZ9VDSB3: 90° flat duct bend Vertical(small radius)
- HEZ9VDSM1: Straight tube 500mm
- HEZ9VRPD0: Basic kit (partly-)ducted recirculation
- HEZ9VDSM2: Straight tube 1000mm
- HEZ9VEDU0: Acoustics filter
- HEZ9VRCR0: cleanAir recirculation replenishment filter
- HEZ9VRUD0: Kit Unducted Recirculation



Cooking starts much faster:

- The QuickStart function detects where you have placed the pot and automatically displays the corresponding cooking zone on the control interface
- You can get started straight away and select the desired cooking level for your pot without delay



PXX875D67E
Serie | 8
80 cm Induction Cooktop
with Integrated Ventilation System

Key highlights:

- **Extraction Rate:** 622 m³/h
- **Noise levels (min/max)** 42 dB / 69 dB
- High-performance, low-noise blower with energy-efficient **BLDC technology**
- **PerfectAir** venting hob removes odours at source, leading to fewer cooking smells in the kitchen.
- **PerfectCook**:** Our hobs are designed with a sensor so you'll be able to control your cooking by the temperature in the pan rather than the power level
- **PerfectFry sensor:** For perfect browning of roasted foods thanks to sensor control with 4 power levels
- **Home Connect** app to remotely monitor/control the hob and its functions through your smartphone/Tab
- **DirectSelect** helps in selection of the desired cooking zone, and additional functions
- **QuickStart** function detects where you have placed the pot
- **ReStart** function stores your control settings

Convenience:

- 4 induction cooking zones with PowerBoost Up to 50%
- 2 combinable zones 'CombiZone' for large pans
- Automatic pan recognition sensor
- Timer with switch-off function: Turns off the assigned cooking zone after the set time
- AutoOn Ventilation for fully-automatic extraction functionality
- Electronic DirectSelect premium touch-control
- MoveMode: The automatic setting of cooking levels allows fast boiling on the front and simmering on the rear cooking zone
- Timer for all zones - shows how long the cooktop is in use

Safety:

- Automatic safety shut off, Control panel lock function
- Child lock
- 2-stage residual heat indicators for each zone
- Wipe protection

Cleaning:

- Saturation indicator
- Cast-iron air inlet grid, heat resistant, dishwasher safe
- Dishwasher safe 12 layer stainless steel 2 grease filters
- Easy to clean as automatic pan recognition only heats up the base of the pan and not the rest of the zone

Technical:

- **Power levels:** 9 + 1 Intensive
- Total connected load 7.4kW
- Metal grease filters
- Nominal voltage (V) 220-240
- Maximum power output (W) 7,400
- Electrical cable length (cm): 110
- 170 Power watt motor
- Variable 17-stage power settings for each zone

Dimensions:

- Appliance Dimension (HxWxD): 223 x 816 x 527 mm
- Cutout Dimension (HxWxD): 223 x 750 x 490-500 mm

*This feature requires the additional purchase of a CookingSensor to operate



PerfectAir Sensor:

- The new PerfectAir sensor constantly monitors the air and automatically adapts the power level to the vapour and odours – continuously, precisely and independently of power settings. At the same time, it reduces the noise level by activating only the minimally required extraction level. When you've finished cooking, the blower continues to run until the kitchen air is cleared of all unpleasant odours.

Optional Accessories:

- HEZ390011: Stainless Steel roaster with glass lid
- HEZ390012: Steaming Rack for Stainless Steel roaster
- HEZ390090: Wok Set consisting of 3 Items
- HEZ390210: System pan diameter 15 cm
- HEZ9LP160: Induction compatible Pot 1.7 Lts
- HEZ390220: System pan diameter 19 cm
- HEZ390230: System pan diameter 21cm
- HEZ39050: Wireless temperature sensor for cooktop
- HEZ390512: Teppan Yaki (large)
- HEZ390522: Griddle plate
- HEZ394301: Installation accessory
- HEZ9CF260: System pan diameter 26cm
- HEZ9LP200: Induction compatible Pot 3.6 Lts
- HEZ9VDSB3: 90° flat duct bend Vertical(small radius)
- HEZ9SE030: Set of 2 pots and 1 pan
- HEZ9VDSB1: 90° flat duct bend horizontal
- HEZ9VDSB2: 90° flat duct bend vertical
- HEZ9VDSM1: Straight tube 500mm
- HEZ9VRPD0: Basic kit (partly-)ducted recirculation
- HEZ9VDSM2: Straight tube 1000mm
- HEZ9VEDU0: Acoustics filter
- HEZ9VRCR0: cleanAir recirculation replenishment filter
- HEZ9VRUD0: Kit Unducted Recirculation

Technical Diagrams

All descriptions and technical diagrams are intended as a guide only. For additional technical information, full dimensional and installation details, please refer to the instruction and installation manuals supplied with the appliance. All measurements in mm.

PVQ811F15E

measurements in mm

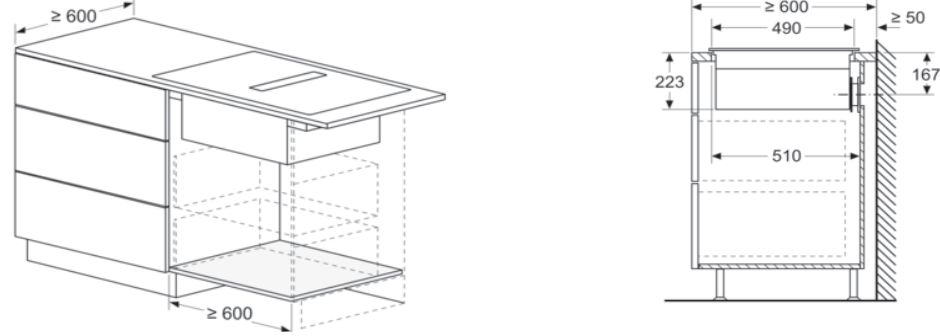

PXX875D67E

measurements in mm

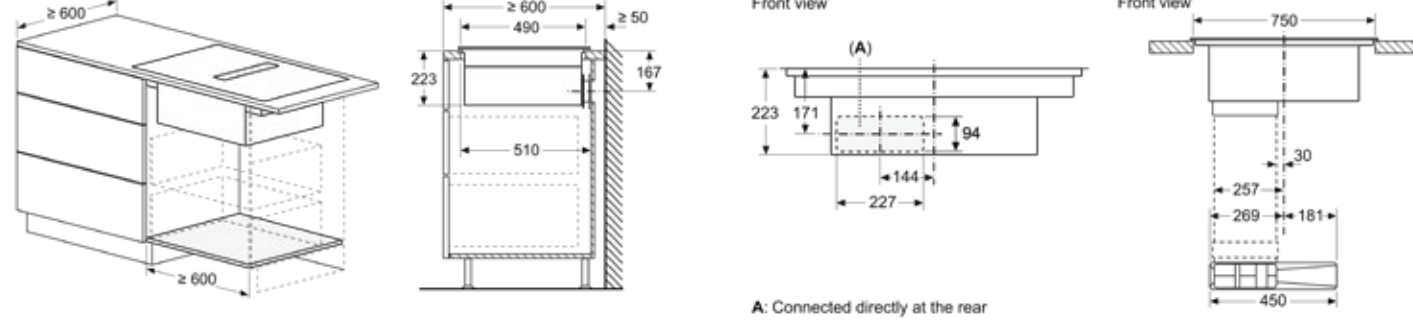

A: Connected directly at the rear

measurements in mm

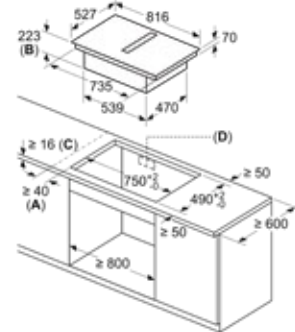

measurements in mm

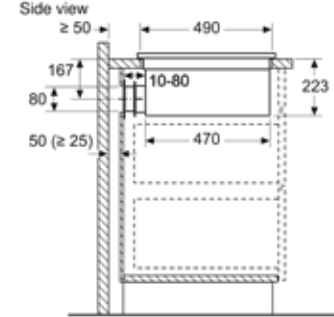

measurements in mm
Front view - unit cut-out
for unducted recirculation

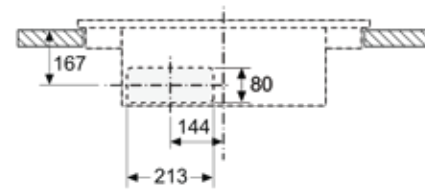

- A: Minimum distance from the hob cut-out to the wall
- B: Recessing depth
- C: The worktop into which the hob is installed must withstand loads of approx. 60kg; suitable substructures must be used if required.
- D: Cut-out in back panel required for pipework. Exact size and position can be taken from specific drawing.



Cooktops



Turn up the knob and
your skills to cook, too.

Enhance your cooking experience by turning on the knob of a hob which delivers quality to your food and revives your passion to cook meals at home.



Key Innovations

Specific features vary by model



FlameSelect: Our Hobs' StepValve technology regulates the gas output precisely so that you can choose the size of the flame. You can also decide what flame you want from the 9 power settings and fire it up with the easy-to-use setting.



Continuous cast-iron pan support: Withstand tough jobs in the kitchen with panels so firm, which give your cookware stability and you the confidence to cook without breaking a sweat.



Sword Knobs: Ergonomically designed knobs to give you control over the flames and your cooking.



Dual Wok: You can now indulge in your passion for cooking with a wok that appreciates the craft of cooking. It balances being strong and gentle with ease. At high power, it boils water for pasta in a jiffy, and on low power it gently simmers sauces to perfection.

Stretch your cooktop to the max, not yourself.

The FlexInduction cooktop lets you juggle pots and pans of any size, to make your time in the kitchen as quick and convenient as possible.

Key Innovations

Specific features vary by model



powerBoost function: You can cook meals in large pans and save on the cooking time too with our induction hobs that have a turbo boost function which increases the power of the cooking zone by 50%.



Freeze function: The Freeze function makes cleaning the hob easier if it gets stained when you cook by freezing all the heat settings of the hob. After cleaning up, you switch it off, and the previous heat settings will get restored.

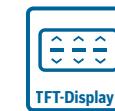

TFT Display: An integrated touch display with clear text and picture allows you to operate the induction hob with ease.



Extended FlexZone: Enjoy the convenience of automatically setting the recommended power level and cooking time for countless dishes. Get more flexibility by combining the cooking zones into one big zone. This makes it super convenient for placing small pots and large cookware.



DirectSelect: Set the right heat level and temperature at the touch of a single button. Models with DirectSelect Premium give you more control over your cooking with an additional minimum temperature setting.



Home Connect[^]: Turn your appliance on and off from anywhere, with the Easy Monitoring feature from your phone. Set different timers for cooking zones or independent zones. Try the Remote Control feature to set an egg timer or the count-up timer. Keep your kids safe by activating or deactivating child lock via Safe & Sound feature on the app. Explore the World of Recipes and discover ingredients and preparation steps. This feature also let you transfer recommendations to the cooktop through Home Connect. You'll also be happy to know, the Hob Hood Sync feature lets the Induction Hob communicate with the chimney, that gets activated when the cookware is heated. Now isn't that intuitive?

What's better than fusion food? A fusion cooking space.

Mix and match your cooktops however you want to make your cooking space, a designer one.



Picture is for representation purpose only.



Key Innovations

Specific features vary by model



Wok Burner: Hosting an oriental cuisine night at home just got super easy. With dual wok burners that are designed to handle all the moves of street style cooking, you can cook up a dragon of an oriental meal at home with ease.



Teppanyaki: Immerse yourself in cooking an authentic Japanese meal with the teppanyaki. Flip shrimp, grill meat, fry light veggies, seafood, and even make savoury Japanese pancakes. Its high-quality steel surface delivers that remarkable Japanese flavour to your food and comes with a ceramic cover and touch slide controls too.



Induction: The induction hob takes care of meal preparations in its unique style. With even heat distribution, it heats the entire pan in no time and saves you from longer cooking hours in an energy-efficient way.



PCH6A6M90I
Serie | 6
Black enamel gas cooktop,
60 cm

Key highlights:

- 4 burners (1 Wok burner, 3 standard burners) with **FlameSelect**® valve technology
- Four powerful gas burners allows you to cook multiple dishes with a full range BTU performance

Heating Functions (Burner/Zone output):

- Front left burner power (kW): 1.75
- Back left burner power (kW): 1.75
- Front right burner power (kW): 1.00
- Back right burner power (kW): 3.50

Convenience:

- One-hand ignition via sword control knobs
- Enamelled cast-iron pan supports

Safety:

- Flame failure safety device

Technical:

- Nominal voltage (V) 220-240
- Maximum gas power output load (W) 8000
- Total connected electrical load (W) 1.0
- Cable length (cm): 100

Dimensions:

- Overall appliance dimension (HXWXD): 45 x 582 x 520 mm
- Cut out dimension (HXWXD): 45 x 560-562 x 480-492 mm

Optional Accessories:

- HEZ211310: Simmer cap
- HEZ298105: Simmer plate
- HEZ298108: Wok ring
- HEZ298115: Small pot support



PCH6A5M90I
Serie | 6
Stainless steel gas cooktop,
60 cm

Key highlights:

- 4 burners with **FlameSelect**® valve technology
- Elegant stainless-steel design

Heating Functions (Burner/Zone output):

- Front left burner power (kW): 1.75
- Back left burner power (kW): 1.75
- Front right burner power (kW): 1.00
- Back right burner power (kW): 3.50

Convenience:

- One-hand ignition via sword control knobs

Safety:

- Flame failure safety device

Technical:

- Nominal voltage (V) 220-240
- Maximum gas power output load (W) 10
- Total connected electrical load (W) 1.0
- Cable length (cm): 100

Dimensions:

- Overall appliance dimension (HXWXD): 45 x 582 x 520 mm
- Cut out dimension (HXWXD): 45 x 560-562 x 480-492 mm

Optional Accessories:

- HEZ211310: Simmer cap
- HEZ298105: Simmer plate
- HEZ298108: Wok ring
- HEZ298115: Small pot support



PCR9A5B90I
Serie | 6
Stainless steel gas cooktop,
90 cm

Key highlights:

- 5 burners with **FlameSelect**® valve technology
- Dual wok burner for very powerful cooking at up to 5 kW (depending on gas type)
- Elegant stainless-steel design

Heating Functions (Burner/Zone output):

- Front left burner power (kW): 1.00
- Back left burner power (kW): 1.75
- Centre/Centre front burner power (kW): 5.00
- Front right burner power (kW): 1.75
- Back right burner power (kW): 3.00

Convenience:

- One-hand ignition via sword control knobs
- Enamelled cast-iron pan supports
- Support

Safety:

- Flame failure safety device

Technical :

- Nominal voltage (V) 220-240
- Maximum gas power output load (W) 12500
- Total connected electrical load (W) 1.0
- Cable length (cm): 150

Dimensions:

- Overall appliance dimension (HXWXD): 45 x 915 x 520 mm
- Cut out dimension (HXWXD): 45 x 850 x 490 - 502 mm

Optional Accessories:

- HEZ211310: Simmer cap
- HEZ298105: Simmer plate
- HEZ298107: Wok ring
- HEZ298115: Small pot



PRS9A6D70I
Serie | 8
Black ceramic gas cooktop,
90 cm

Key highlights:

- 4 burners + 1 wok (left) with **FlameSelect**® valve technology
- Dual wok burner for very powerful cooking at up to 6 kW (depending on gas type)
- Residual heat indicator
- Schott Ceramic design

Heating Functions (Burner/Zone output):

- Left burner power (kW): 6
- Centre/Centre front burner power (kW): 1.75
- Centre back burner power (kW): 1.00
- Front right burner power (kW): 1.75
- Back right burner power (kW): 3.00

Convenience:

- One-hand ignition via sword control knobs
- Dishwasher safe enamelled cast-iron pan supports
- Standard and semi-flush built-in option

Safety:

- Flame failure safety device

Technical :

- Nominal voltage (V) 220-240
- Maximum gas power output load (W) 13700
- Total connected electrical load (W) 1.0
- Cable length (cm): 150

Dimensions:

- Overall appliance dimension (HXWXD): 45 x 916 x 527 mm
- Cut out dimension (HXWXD): 45 x 850-852 x 490 - 502 mm

Included Accessories:

- 1 x WOK attachment ring

Optional Accessories:

- HEZ298010: Nozzle set liquid gas G30/50mbar
- HEZ298105: Simmer plate
- HEZ298114: Small pot support

Smart Design:

- Square design pan supports don't just look good, but provide more stability for pots and pans
- Cleverly designed to fit together, they are separate pieces, which make them easy to handle and clean
- The elegant tempered glass base allows for a choice of surface mounting for quick and easy installation, or flush mounting

A touch of the Orient:

- Powerful, dual ring wok burners are perfect for oriental cooking
- They deliver a boost both in power and speed, but can also be used very effectively at lower settings when required
- Powerful cooking at up to 6 kW (depending on gas type)



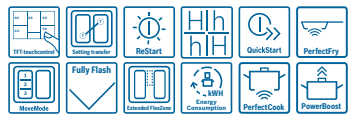
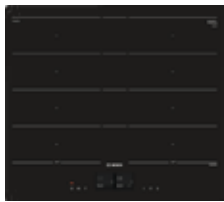

PXY601JW1E
Serie | 8
Induction Cooktop,
60 cm

Key highlights:

- 4 induction cooking zones with **PowerBoost** saves up to 50% more power for faster heating
- 2 combinable zones '**CombiZone**' for large pans
- **PerfectFry** sensor with 5 automatic frying programs
- **PerfectCook** feature in our hobs are designed with a sensor so you'll be able to control your cooking by the temperature in the pan rather than the power level.
- **MoveMode** function with 3 automatic power levels
- **Express cooking** through the Boost function allows you to increase the power of the cooking zone by 50%
- **ReStart:** Stores your control settings
- **QuickStart:** detects where you have placed the pot
- **DirectSelect** helps in selection of the desired cooking zone, power and additional functions
- **Home Connect** app to remotely monitor/control the hob and its functions through your smartphone/Tab

Convenience:

- Automatic pan recognition sensor
- Automatic Temperature Control
- Switch off timer for every cooking zone.
- Flush fitting design/installation

Safety:

- Automatic safety switch off and Wipe protection function
- Child lock
- 2 stage residual heat indicators in each zone, Power Management function

Cleaning:

- Easy to Clean as automatic pan recognition only heats up the base of the pan and not the rest of the zone, leaves the rest of the hob cool to touch
- In case of any spills, simply select the **Freeze function** which freezes all the heat settings

Technical:

- Nominal voltage (V) 220-240
- Maximum power output (W) 7,400
- Electrical cable length (cm) 110
- Variable 17-stage power settings for each zone

Dimensions:

- Min. worktop thickness: 16 mm (HxWxD): 56 x 572 x 512 mm

Optional Accessories:

- HEZ390011: Stainless Steel roaster with glass lid
- HEZ390012: Steaming Rack for Stainless Steel roaster
- HEZ390042: Set of 3 pots and 1 pan
- HEZ390090: Wok Set consisting of 3 Items
- HEZ390210: System pan diameter 15 cm
- HEZ390220: System pan diameter 19 cm
- HEZ390230: System pan diameter 21cm
- HEZ390250: System pan diameter 28 cm
- HEZ39050: Wireless temperature sensor for cooktop
- HEZ390511: Teppan Yaki (small)
- HEZ390512: Teppan Yaki (large)
- HEZ390522: Griddle Plate
- HEZ395600: Inlay-frame 60cm
- HEZ395601: Pattern for

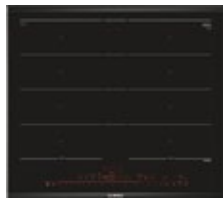

PXY675DW4E
Serie | 8
Induction Cooktop,
60 cm

Key highlights:

- 4 induction cooking zones with **PowerBoost** saves up to 50% more power for faster heating
- 2 combinable zones '**CombiZone**' for large pans
- **PerfectFry** sensor with 5 automatic frying programs
- **PerfectCook** feature in our hobs are designed with a sensor so you'll be able to control your cooking by the temperature in the pan rather than the power level.
- **MoveMode** function with 3 automatic power levels
- **Express cooking** through the Boost function allows you to increase the power of the cooking zone by 50%
- **ReStart:** Stores your control settings
- **QuickStart:** detects where you have placed the pot
- **DirectSelect** helps in selection of the desired cooking zone, power and additional functions
- **Home Connect** app to remotely monitor/control the hob and its functions through your smartphone/Tab

Convenience:

- Automatic pan recognition sensor
- ComfortProfile: Elegant, appealing design with bevelled front and metal strips on the side
- Automatic Temperature Control
- Switch off timer for every cooking zone.
- Flush fitting design/installation

Safety:

- Automatic safety switch off and Wipe protection function
- Child lock
- 2 stage residual heat indicators in each zone, Power Management function

Cleaning:

- Easy to Clean as automatic pan recognition only heats up the base of the pan and not the rest of the zone, leaves the rest of the hob cool to touch
- In case of any spills, simply select the **Freeze function** which freezes all the heat settings

Technical:

- Nominal voltage (V) 220-240
- Maximum power output (W) 7,400
- Electrical cable length (cm) 110
- Variable 17-stage power settings for each zone

Dimensions:

- Min. worktop thickness: 30 mm (HxWxD): 51 x 606 x 527 mm

Optional Accessories:

- HEZ390011: Stainless Steel roaster with glass lid
- HEZ390012: Steaming Rack for Stainless Steel roaster
- HEZ390090: Wok Set consisting of 3 Items
- HEZ390210: System pan diameter 15 cm
- HEZ390220: System pan diameter 19 cm
- HEZ390230: System pan diameter 21cm
- HEZ390250: System pan diameter 28 cm
- HEZ39050: Wireless temperature sensor for cooktop
- HEZ390511: Teppan Yaki (small)
- HEZ390512: Teppan Yaki (large)
- HEZ390522: Griddle Plate
- HEZ395600: Inlay-frame 60cm
- HEZ395601: Pattern for
- HEZ395602: Pattern for
- HEZ395603: Pattern for
- HEZ395604: Pattern for
- HEZ395605: Pattern for
- HEZ395606: Pattern for
- HEZ395607: Pattern for
- HEZ395608: Pattern for
- HEZ395609: Pattern for
- HEZ395610: Pattern for
- HEZ395611: Pattern for
- HEZ395612: Pattern for
- HEZ395613: Pattern for
- HEZ395614: Pattern for
- HEZ395615: Pattern for
- HEZ395616: Pattern for
- HEZ395617: Pattern for
- HEZ395618: Pattern for
- HEZ395619: Pattern for
- HEZ395620: Pattern for
- HEZ395621: Pattern for
- HEZ395622: Pattern for
- HEZ395623: Pattern for
- HEZ395624: Pattern for
- HEZ395625: Pattern for
- HEZ395626: Pattern for
- HEZ395627: Pattern for
- HEZ395628: Pattern for
- HEZ395629: Pattern for
- HEZ395630: Pattern for
- HEZ395631: Pattern for
- HEZ395632: Pattern for
- HEZ395633: Pattern for
- HEZ395634: Pattern for
- HEZ395635: Pattern for
- HEZ395636: Pattern for
- HEZ395637: Pattern for
- HEZ395638: Pattern for
- HEZ395639: Pattern for
- HEZ395640: Pattern for
- HEZ395641: Pattern for
- HEZ395642: Pattern for
- HEZ395643: Pattern for
- HEZ395644: Pattern for
- HEZ395645: Pattern for
- HEZ395646: Pattern for
- HEZ395647: Pattern for
- HEZ395648: Pattern for
- HEZ395649: Pattern for
- HEZ395650: Pattern for
- HEZ395651: Pattern for
- HEZ395652: Pattern for
- HEZ395653: Pattern for
- HEZ395654: Pattern for
- HEZ395655: Pattern for
- HEZ395656: Pattern for
- HEZ395657: Pattern for
- HEZ395658: Pattern for
- HEZ395659: Pattern for
- HEZ395660: Pattern for
- HEZ395661: Pattern for
- HEZ395662: Pattern for
- HEZ395663: Pattern for
- HEZ395664: Pattern for
- HEZ395665: Pattern for
- HEZ395666: Pattern for
- HEZ395667: Pattern for
- HEZ395668: Pattern for
- HEZ395669: Pattern for
- HEZ395670: Pattern for
- HEZ395671: Pattern for
- HEZ395672: Pattern for
- HEZ395673: Pattern for
- HEZ395674: Pattern for
- HEZ395675: Pattern for
- HEZ395676: Pattern for
- HEZ395677: Pattern for
- HEZ395678: Pattern for
- HEZ395679: Pattern for
- HEZ395680: Pattern for
- HEZ395681: Pattern for
- HEZ395682: Pattern for
- HEZ395683: Pattern for
- HEZ395684: Pattern for
- HEZ395685: Pattern for
- HEZ395686: Pattern for
- HEZ395687: Pattern for
- HEZ395688: Pattern for
- HEZ395689: Pattern for
- HEZ395690: Pattern for
- HEZ395691: Pattern for
- HEZ395692: Pattern for
- HEZ395693: Pattern for
- HEZ395694: Pattern for
- HEZ395695: Pattern for
- HEZ395696: Pattern for
- HEZ395697: Pattern for
- HEZ395698: Pattern for
- HEZ395699: Pattern for
- HEZ395700: Pattern for
- HEZ395701: Pattern for
- HEZ395702: Pattern for
- HEZ395703: Pattern for
- HEZ395704: Pattern for
- HEZ395705: Pattern for
- HEZ395706: Pattern for
- HEZ395707: Pattern for
- HEZ395708: Pattern for
- HEZ395709: Pattern for
- HEZ395710: Pattern for
- HEZ395711: Pattern for
- HEZ395712: Pattern for
- HEZ395713: Pattern for
- HEZ395714: Pattern for
- HEZ395715: Pattern for
- HEZ395716: Pattern for
- HEZ395717: Pattern for
- HEZ395718: Pattern for
- HEZ395719: Pattern for
- HEZ395720: Pattern for
- HEZ395721: Pattern for
- HEZ395722: Pattern for
- HEZ395723: Pattern for
- HEZ395724: Pattern for
- HEZ395725: Pattern for
- HEZ395726: Pattern for
- HEZ395727: Pattern for
- HEZ395728: Pattern for
- HEZ395729: Pattern for
- HEZ395730: Pattern for
- HEZ395731: Pattern for
- HEZ395732: Pattern for
- HEZ395733: Pattern for
- HEZ395734: Pattern for
- HEZ395735: Pattern for
- HEZ395736: Pattern for
- HEZ395737: Pattern for
- HEZ395738: Pattern for
- HEZ395739: Pattern for
- HEZ395740: Pattern for
- HEZ395741: Pattern for
- HEZ395742: Pattern for
- HEZ395743: Pattern for
- HEZ395744: Pattern for
- HEZ395745: Pattern for
- HEZ395746: Pattern for
- HEZ395747: Pattern for
- HEZ395748: Pattern for
- HEZ395749: Pattern for
- HEZ395750: Pattern for
- HEZ395751: Pattern for
- HEZ395752: Pattern for
- HEZ395753: Pattern for
- HEZ395754: Pattern for
- HEZ395755: Pattern for
- HEZ395756: Pattern for
- HEZ395757: Pattern for
- HEZ395758: Pattern for
- HEZ395759: Pattern for
- HEZ395760: Pattern for
- HEZ395761: Pattern for
- HEZ395762: Pattern for
- HEZ395763: Pattern for
- HEZ395764: Pattern for
- HEZ395765: Pattern for
- HEZ395766: Pattern for
- HEZ395767: Pattern for
- HEZ395768: Pattern for
- HEZ395769: Pattern for
- HEZ395770: Pattern for
- HEZ395771: Pattern for
- HEZ395772: Pattern for
- HEZ395773: Pattern for
- HEZ395774: Pattern for
- HEZ395775: Pattern for
- HEZ395776: Pattern for
- HEZ395777: Pattern for
- HEZ395778: Pattern for
- HEZ395779: Pattern for
- HEZ395780: Pattern for
- HEZ395781: Pattern for
- HEZ395782: Pattern for
- HEZ395783: Pattern for
- HEZ395784: Pattern for
- HEZ395785: Pattern for
- HEZ395786: Pattern for
- HEZ395787: Pattern for
- HEZ395788: Pattern for
- HEZ395789: Pattern for
- HEZ395790: Pattern for
- HEZ395791: Pattern for
- HEZ395792: Pattern for
- HEZ395793: Pattern for
- HEZ395794: Pattern for
- HEZ395795: Pattern for
- HEZ395796: Pattern for
- HEZ395797: Pattern for
- HEZ395798: Pattern for
- HEZ395799: Pattern for
- HEZ395800: Pattern for
- HEZ395801: Pattern for
- HEZ395802: Pattern for
- HEZ395803: Pattern for
- HEZ395804: Pattern for
- HEZ395805: Pattern for
- HEZ395806: Pattern for
- HEZ395807: Pattern for
- HEZ395808: Pattern for
- HEZ395809: Pattern for
- HEZ395810: Pattern for
- HEZ395811: Pattern for
- HEZ395812: Pattern for
- HEZ395813: Pattern for
- HEZ395814: Pattern for
- HEZ395815: Pattern for
- HEZ395816: Pattern for
- HEZ395817: Pattern for
- HEZ395818: Pattern for
- HEZ395819: Pattern for
- HEZ395820: Pattern for
- HEZ395821: Pattern for
- HEZ395822: Pattern for
- HEZ395823: Pattern for
- HEZ395824: Pattern for
- HEZ395825: Pattern for
- HEZ395826: Pattern for
- HEZ395827: Pattern for
- HEZ395828: Pattern for
- HEZ395829: Pattern for
- HEZ395830: Pattern for
- HEZ395831: Pattern for
- HEZ395832: Pattern for
- HEZ395833: Pattern for
- HEZ395834: Pattern for
- HEZ395835: Pattern for
- HEZ395836: Pattern for
- HEZ395837: Pattern for
- HEZ395838: Pattern for
- HEZ395839: Pattern for
- HEZ395840: Pattern for
- HEZ395841: Pattern for
- HEZ395842: Pattern for
- HEZ395843: Pattern for
- HEZ395844: Pattern for
- HEZ395845: Pattern for
- HEZ395846: Pattern for
- HEZ395847: Pattern for
- HEZ395848: Pattern for
- HEZ395849: Pattern for
- HEZ395850: Pattern for
- HEZ395851: Pattern for
- HEZ395852: Pattern for
- HEZ395853: Pattern for
- HEZ395854: Pattern for
- HEZ395855: Pattern for
- HEZ395856: Pattern for
- HEZ395857: Pattern for
- HEZ395858: Pattern for
- HEZ395859: Pattern for
- HEZ395860: Pattern for
- HEZ395861: Pattern for
- HEZ395862: Pattern for
- HEZ395863: Pattern for
- HEZ395864: Pattern for
- HEZ395865: Pattern for
- HEZ395866: Pattern for
- HEZ395867: Pattern for
- HEZ395868: Pattern for
- HEZ395869: Pattern for
- HEZ395870: Pattern for
- HEZ395871: Pattern for
- HEZ395872: Pattern for
- HEZ395873: Pattern for
- HEZ395874: Pattern for
- HEZ395875: Pattern for
- HEZ395876: Pattern for
- HEZ395877: Pattern for
- HEZ395878: Pattern for
- HEZ395879: Pattern for
- HEZ395880: Pattern for
- HEZ395881: Pattern for
- HEZ395882: Pattern for
- HEZ395883: Pattern for
- HEZ395884: Pattern for
- HEZ395885: Pattern for
- HEZ395886: Pattern for
- HEZ395887: Pattern for
- HEZ395888: Pattern for
- HEZ395889: Pattern for
- HEZ395890: Pattern for
- HEZ395891: Pattern for
- HEZ395892: Pattern for
- HEZ395893: Pattern for
- HEZ395894: Pattern for
- HEZ395895: Pattern for
- HEZ395896: Pattern for
- HEZ395897: Pattern for
- HEZ395898: Pattern for
- HEZ395899: Pattern for
- HEZ395900: Pattern for
- HEZ395901: Pattern for
- HEZ395902: Pattern for
- HEZ395903: Pattern for
- HEZ395904: Pattern for
- HEZ395905: Pattern for
- HEZ395906: Pattern for
- HEZ395907: Pattern for
- HEZ395908: Pattern for
- HEZ395909: Pattern for
- HEZ395910: Pattern for
- HEZ395911: Pattern for
- HEZ395912: Pattern for
- HEZ395913: Pattern for
- HEZ395914: Pattern for
- HEZ395915: Pattern for
- HEZ395916: Pattern for
- HEZ395917: Pattern for
- HEZ395918: Pattern for
- HEZ395919: Pattern for
- HEZ395920: Pattern for
- HEZ395921: Pattern for
- HEZ395922: Pattern for
- HEZ395923: Pattern for
- HEZ395924: Pattern for
- HEZ395925: Pattern for
- HEZ395926: Pattern for
- HEZ395927: Pattern for
- HEZ395928: Pattern for
- HEZ395929: Pattern for
- HEZ395930: Pattern for
- HEZ395931: Pattern for
- HEZ395932: Pattern for
- HEZ395933: Pattern for
- HEZ395934: Pattern for
- HEZ395935: Pattern for
- HEZ395936: Pattern for
- HEZ395937: Pattern for
- HEZ395938: Pattern for
- HEZ395939: Pattern for
- HEZ395940: Pattern for
- HEZ395941: Pattern for
- HEZ395942: Pattern for
- HEZ395943: Pattern for
- HEZ395944: Pattern for
- HEZ395945: Pattern for
- HEZ395946: Pattern for
- HEZ395947: Pattern for
- HEZ395948: Pattern for
- HEZ395949: Pattern for
- HEZ395950: Pattern for
- HEZ395951: Pattern for
- HEZ395952: Pattern for
- HEZ395953: Pattern for
- HEZ395954: Pattern for
- HEZ395955: Pattern for
- HEZ395956: Pattern for
- HEZ395957: Pattern for
- HEZ395958: Pattern for
- HEZ395959: Pattern for
- HEZ395960: Pattern for
- HEZ395961: Pattern for
- HEZ395962: Pattern for
- HEZ395963: Pattern for
- HEZ395964: Pattern for
- HEZ395965: Pattern for
- HEZ395966: Pattern for
- HEZ395967: Pattern for
- HEZ395968: Pattern for
- HEZ395969: Pattern for
- HEZ395970: Pattern for
- HEZ395971: Pattern for
- HEZ395972: Pattern for
- HEZ395973: Pattern for
- HEZ395974: Pattern for
- HEZ395975: Pattern for
- HEZ395976: Pattern for
- HEZ395977: Pattern for
- HEZ395978: Pattern for
- HEZ395979: Pattern for
- HEZ395980: Pattern for
- HEZ395981: Pattern for
- HEZ395982: Pattern for
- HEZ395983: Pattern for
- HEZ395984: Pattern for
- HEZ395985: Pattern for
- HEZ395986: Pattern for
- HEZ395987: Pattern for
- HEZ395988: Pattern for
- HEZ395989: Pattern for
- HEZ395990: Pattern for
- HEZ395991: Pattern for
- HEZ395992: Pattern for
- HEZ395993: Pattern for
- HEZ395994: Pattern for
- HEZ395995: Pattern for
- HEZ395996: Pattern for
- HEZ395997: Pattern for
- HEZ395998: Pattern for
- HEZ395999: Pattern for
- HEZ396000: Pattern for



PerfectFry:

- For perfect browning of roasted foods thanks to sensor control with 4 power levels.
- Switch off timer for every cooking zone. Count down function count-up timer, per cooktop

Automatic pan recognition:

- Automatic pan recognition only heats up the base of the pan and not the rest of the zone, which doesn't waste energy and leaves the rest of the hob cool to touch
- Keeping the hob cooler makes it safer and also prevents spillages from burning on so it's easy to clean



Cooking starts much faster:

- The QuickStart function detects where you have placed the pot and automatically displays the corresponding cooking zone on the control interface
- You can get started straight away and select the desired cooking level for your pot without delay



PXX375FB5I
Serie | 6
FlexInduction Cooktop,
30 cm

Key highlights:

- 2 induction cooking zones with PowerBoost saves up to 50% more power for faster heating
- **PerfectFry** sensor with 4 automatic frying programs
- Ultimate flexibility with **FlexInduction** wherein you can combine two induction zones into a large induction surface
- **DirectSelect** helps in selection of the desired cooking zone, power and additional functions
- **MoveMode** function is the automatic setting of cooking levels which allows fast boiling on the front and simmering on the rear cooking zone
- **QuickStart function** detects where you have placed the pot
- **ReStart function** stores your control settings

Convenience:

- Automatic pan recognition sensor
- **Timer with switch-off function** turns off the assigned cooking zone after the set time
- Can be combined with all hobs in comfort design
- 7-segment energy consumption display
- Comfort profile (ceramic front facette with stainless steel side trim)
- Power boost functions for all zones

Safety:

- Power management function, Automatic safety switch off
- Safety lock
- 2 stage residual heat indicators for each zone

Cleaning:

- Easy to Clean as automatic pan recognition only heats up the base of the pan and not the rest of the zone and leaves the rest of the hob cool to touch and clean

Technical:

- Maximum power output(W) 3700
- Variable 17-stage power settings for each zone

Dimensions:

- Appliance Dimension (HxWxD): 51 x 306 x 527 mm
- Cut out Dimension (HxWxD): 51 x 270 x 490-500 mm



PKY475FB1E
Serie | 6
Teppanyaki Module,
40 cm

Key highlights:

Technical Diagrams

All descriptions and technical diagrams are intended as a guide only. For additional technical information, full dimensional and installation details, please refer to the instruction and installation manuals supplied with the appliance. All measurements in mm.

Hob

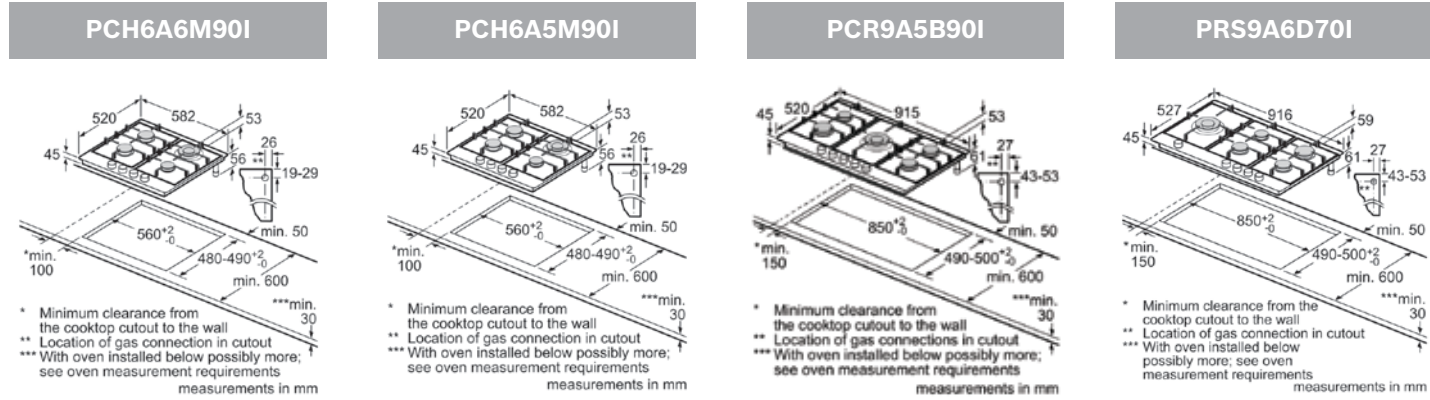

Induction

PXY601JW1E

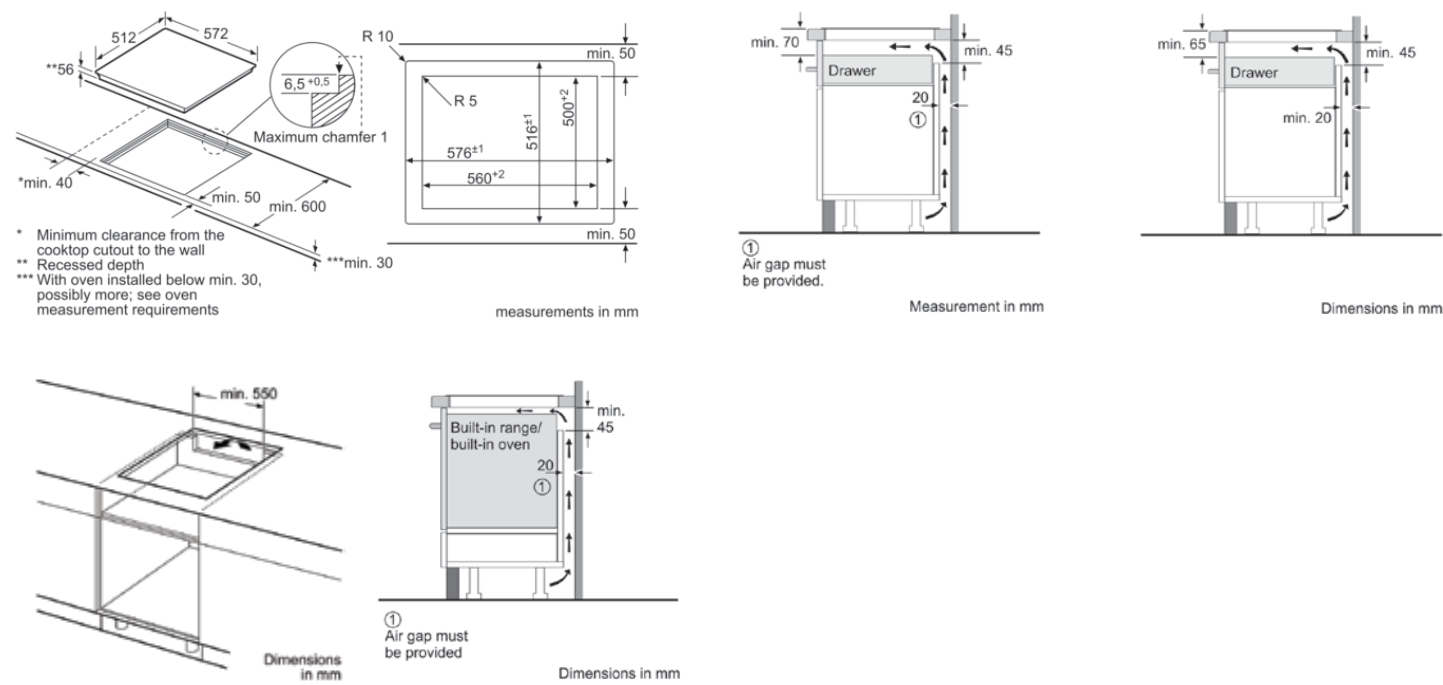

PXY675DW4E

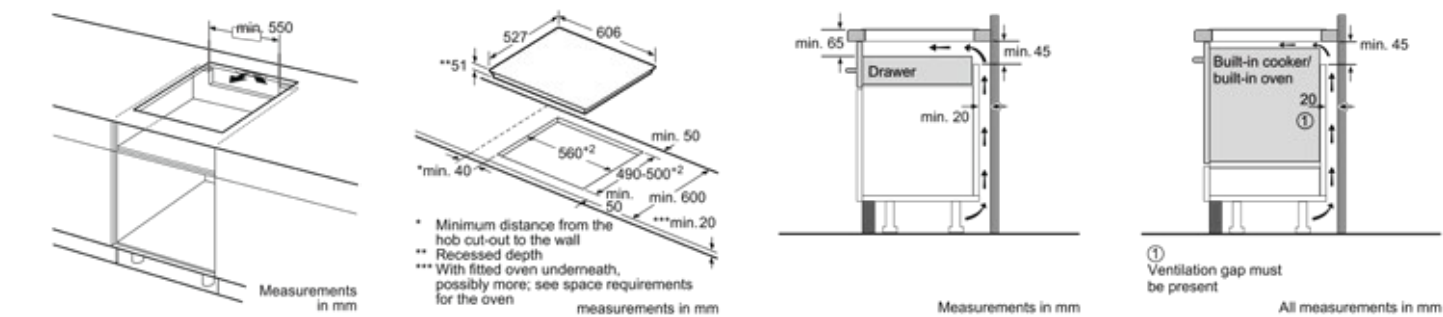

Technical Diagrams

All descriptions and technical diagrams are intended as a guide only. For additional technical information, full dimensional and installation details, please refer to the instruction and installation manuals supplied with the appliance. All measurements in mm.

Dominos

PXX375FB1E

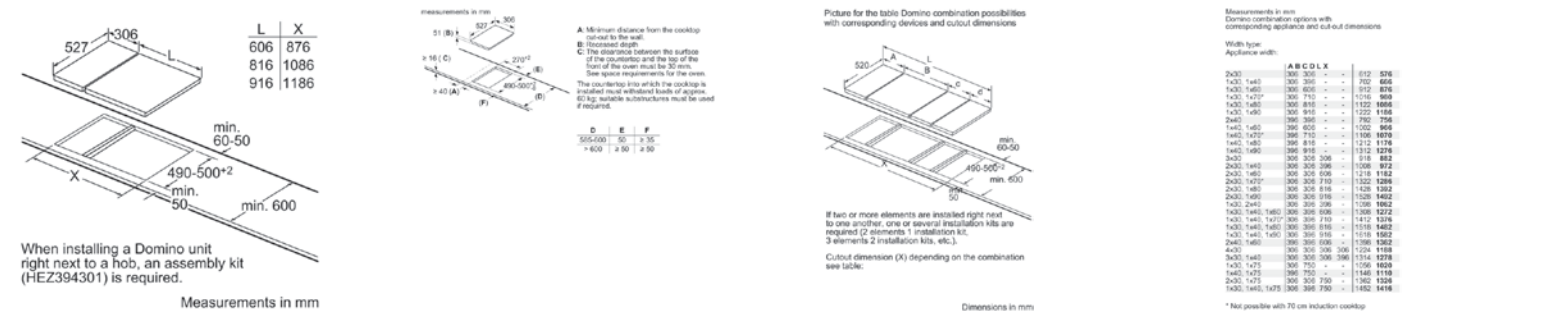
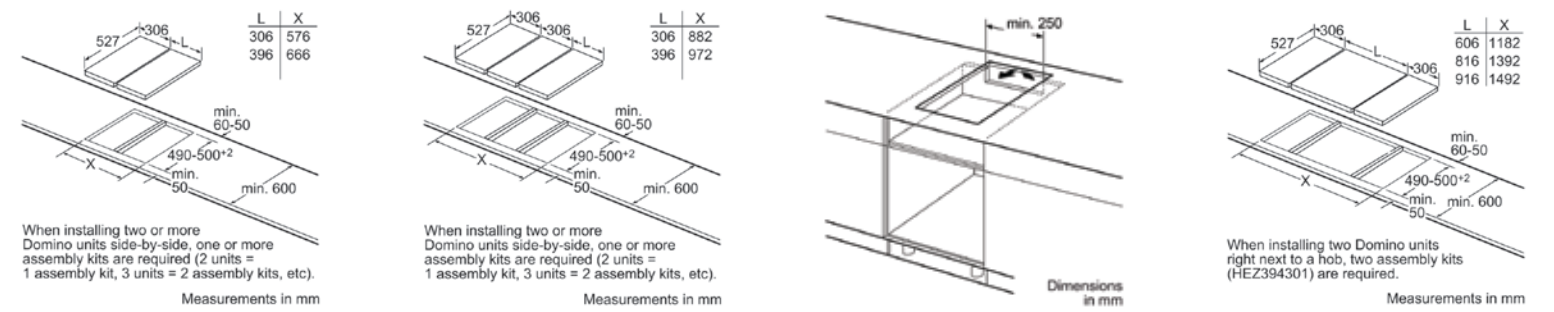
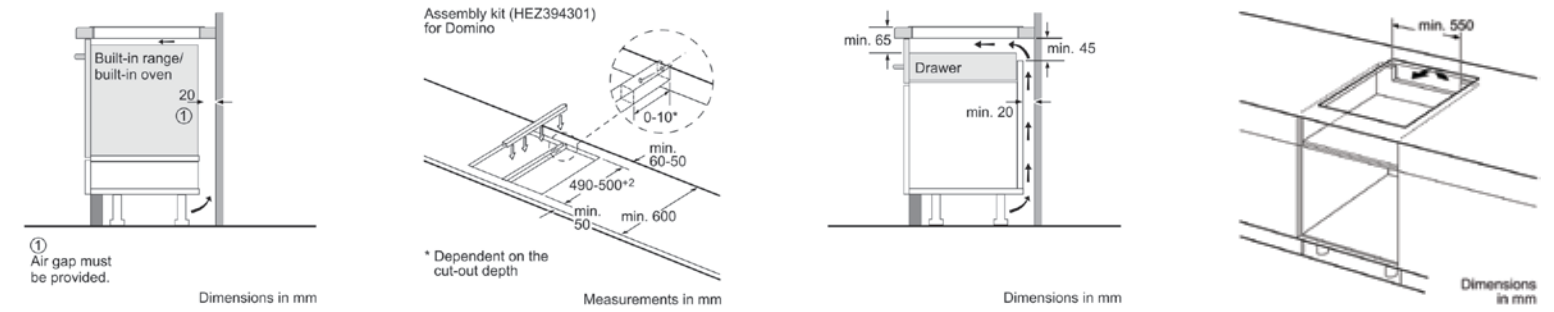

PRA3A6D70

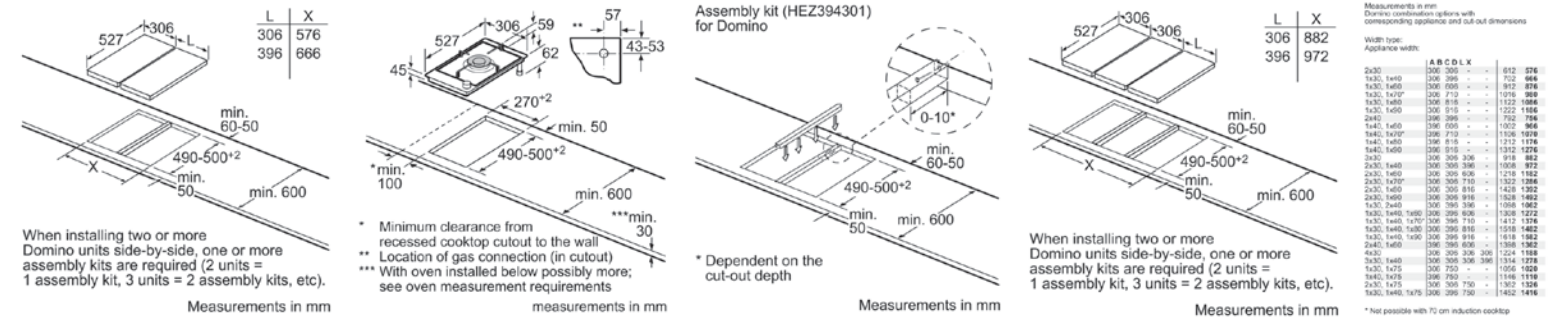

Technical Diagrams

All descriptions and technical diagrams are intended as a guide only. For additional technical information, full dimensional and installation details, please refer to the instruction and installation manuals supplied with the appliance. All measurements in mm.

PRA3A6D70

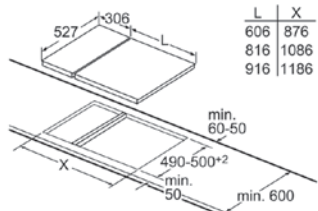

When installing a Domino unit right next to a hob, an assembly kit (HEZ394301) is required.

Measurements in mm

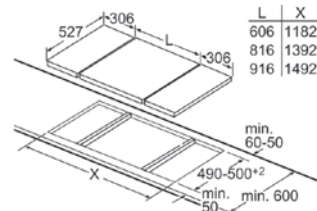

When installing two Domino units right next to a hob, two assembly kits (HEZ394301) are required.

Measurements in mm

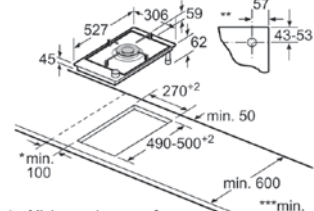

* Minimum clearance from recessed cooktop cutout to the wall
 ** Location of gas connection (in cutout)
 *** With oven installed below possibly more; see oven measurement requirements

measurements in mm

Picture for the table Domino combination possibilities with corresponding devices and cutout dimensions

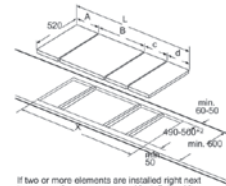

If two or more elements are installed right next to one another, one or several installation kits are required (2 elements 1 installation kit, 3 elements 2 installation kits, etc.).

Cutout dimension (X) depending on the combination see table:

Dimensions in mm

PKY475FB1E

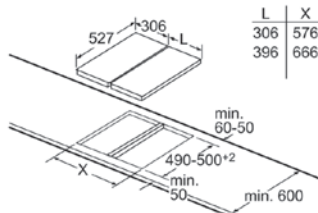

When installing two or more Domino units side-by-side, one or more assembly kits are required (2 units = 1 assembly kit, 3 units = 2 assembly kits, etc).

Measurements in mm

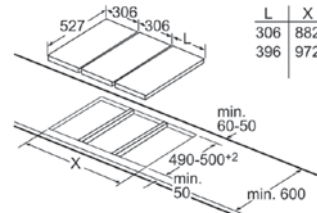

When installing two or more Domino units side-by-side, one or more assembly kits are required (2 units = 1 assembly kit, 3 units = 2 assembly kits, etc).

Measurements in mm

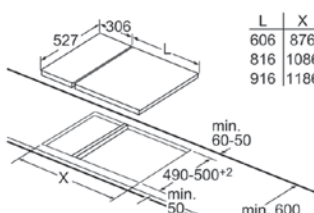

When installing a Domino unit right next to a hob, an assembly kit (HEZ394301) is required.

Measurements in mm

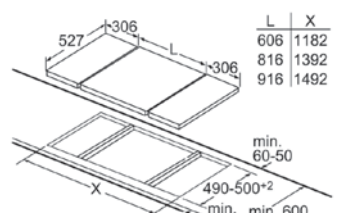

When installing two Domino units right next to a hob, two assembly kits (HEZ394301) are required.

Measurements in mm

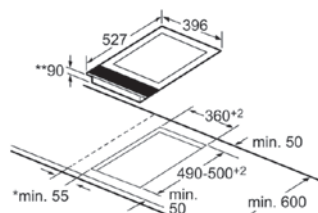

* Minimum distance from the hob cut-out to the wall
 ** Maximum recessed depth

measurements in mm

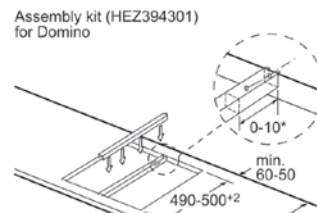

Assembly kit (HEZ394301) for Domino

* Dependent on the cut-out depth

Measurements in mm

Picture for the table Domino combination possibilities with corresponding devices and cutout dimensions

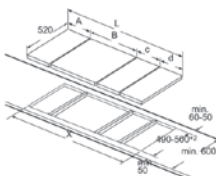

If two or more elements are installed right next to one another, one or several installation kits are required (2 elements 1 installation kit, 3 elements 2 installation kits, etc.).

Cutout dimension (X) depending on the combination see table:

Dimensions in mm

Measurements in mm Domino combination options with corresponding appliance and cut out dimensions

Width type Appliance width:

Appliance width	A	B	C	D	L	X
2000	300	300	-	-	612	976
1400, 1470	300	300	-	-	702	966
1400, 1470	300	600	-	-	912	876
1400, 1470	300	710	-	-	1010	900
1400, 1470	300	816	-	-	1122	1086
1400, 1470	300	916	-	-	1222	1186
2400	300	280	-	-	702	796
1400, 1470	300	600	-	-	1002	900
1400, 1470	300	710	-	-	1100	976
1400, 1470	300	816	-	-	1212	1076
1400, 1470	300	916	-	-	1312	1176
2400	300	300	300	-	918	876
2400, 1470	300	300	300	-	1008	976
2400, 1470	300	300	600	-	1218	1182
2400, 1470	300	300	710	-	1322	1286
2400, 1470	300	300	816	-	1428	1382
2400, 1470	300	300	916	-	1528	1482
1400, 2400	300	280	300	-	1008	1082
1400, 1470, 1480	300	280	600	-	1308	1272
1400, 1480, 1470	300	380	710	-	1412	1376
1400, 1480, 1480	300	380	816	-	1516	1482
1400, 1480, 1490	300	280	916	-	1618	1582
2400, 1480	300	280	600	-	1308	1382
4000	300	300	300	300	1224	1188
3000, 1480	300	300	300	300	1314	1276
1400, 1475	300	750	-	-	1056	1020
1400, 1475	300	750	-	-	1160	1120
2400, 1475	300	300	750	-	1382	1326
1400, 1482, 1475	300	390	750	-	1452	1416

* Not possible with 70 cm induction cooktop



Chimneys





Meet your silent partner in the kitchen.

Bosch chimneys EcoSilence Drive® and PerfectAir sensors keep your kitchen's ambiance fresh, always.

Key Innovations

Specific features vary by model



EcoSilence Drive®: The EcoSilence Drive's brushless friction-free motor's performance will leave you speechless. For starters, it is durable, highly efficient, and saves energy. Additionally, its energy-saving LED lights not only reduce energy consumption by 80% compared to a 5-year model but also give you perfect results.



CleanAir Module: Experience the bliss of a fresh kitchen, thanks to our CleanAir Module feature which absorbs almost 95% odour from the chimney. Now that's what we call maximum air quality at minimum volume.



PerfectAir: Constantly detecting the levels of odour in the air while you cook and automatically adjusting the power for optimum extraction performance is how our PerfectAir sensors work. So, you don't have to worry about the chimney settings anymore but just enjoy the comfort of cooking.



High extraction rate: Leave the job of maintaining ambiance in your kitchen to your Bosch chimney. By setting the delivery volume or power of the cooker hood appropriate to the size of the kitchen, it can provide optimum air volume for kitchens of all sizes.



Home Connect^: Control your appliance from anywhere, with the Easy Monitoring feature that lets you turn it on or off from your phone. Create an atmosphere before you cook with Ambient Lighting, simply adjust the light, colour and intensity your mood and get cooking. Enjoy the Hood Hob Sync - a feature that automatically gets activated when your cookware is heated. Ensure your appliance performs optimally every time with maintenance alert. This notifies you on grease filters and carbon saturation.



Picture is for representation purpose only.

*Please note that this service is only available in English and for the appliances installed in cities - Mumbai, Delhi NCR, Bangalore, Kolkata, Hyderabad, Chennai, Ahmedabad, Pune and Jaipur. For further information please check: www.home-Connect.co.in or contact BSH Household Appliances Mfg. Pvt. Ltd. @ service.in@bosch-home.com



DWB91PR50
Serie | 8
Stainless steel wall chimney,
90 cm

Key Highlights:

- 964m³/h maximum extraction capacity
- **High extraction rate** filters out over 85% of the grease from kitchen air
- **EcoSilence Drive**[®] brushless motor
- **Noise level** 45dB at minimum level (150mm ducted)
- **Home Connect** app to remotely monitor/control the hood and its functions through your smartphone/Tab
- **PerfectAir sensor** automatically detects cooking intensity and adjusts power level
- **Energy efficiency class:** A+
- Cooktop-based hood control ready

Convenience:

- **LED illumination:** The energy-saving lighting provides white and good lighting for the hob area
- Cooktop-based hood control ready
- **Automatic intensive revert** helps power automatically reverts back to normal setting after intensive speed setting
- With the new **DirectSelect** control, you can set the desired power level and control such functions as the PerfectAir sensor, after-running, and lighting level directly

Cleaning:

- **Easy-to-clean interior** with hidden screws and cables along with rounded edges make cleaning easy
- Dishwasher-safe metal grease filters
- Electronic filter saturation indicator

Technology:

- Electronic Control via Touch control with lightline
- 3 power settings + 2 intensive settings with automatic revert
- Automatic run-on time 10 mins
- No. of metal grease filters 3
- Pipe outlet diameter (mm) 150/120

Dimensions:

- Dimensions exhaust air (HxWxD): 614-954 x 898 x 500 mm
- Dimensions recirculating (HxWxD): 614-1064 x 898 x 500 mm

Optional Accessories:

- DHZ1223: Chimney extension 1000 mm
- DHZ1233: Chimney extension 1500 mm
- DHZ5345: Recirculating kit
- DHZ5346: Active carbon filter
- DSZ5201: CleanAir active carbon filter spare part
- DSZ6240: CleanAir Recirculation Kit
- DWZ0XX0I5: Integrated CleanAir Recirculation Kit
- DWZ0XX0J5: Integrated CleanAir Recirculation Kit
- DZZ0XX0P0: CleanAir active carbon filter regenerative



DWB98JR50
Serie | 6
Stainless steel wall chimney,
90 cm

Key Highlights:

- 843 m³/h maximum extraction capacity
- **High extraction rate** filters out over 85% of the grease from kitchen air
- **EcoSilence Drive**[®] brushless motor
- **Noise level** 55dB at minimum level
- **Home Connect** app to remotely monitor/control the hood and its functions through your smartphone/Tab
- **PerfectAir sensor** automatically detects cooking intensity and adjusts power level
- **Energy efficiency class:** A+
- Cooktop-based hood control ready

Convenience:

- **LED illumination:** The energy-saving lighting provides white and good lighting for the hob area
- Cooktop-based hood control ready
- **Automatic intensive revert** helps power automatically reverts back to normal setting after intensive speed setting
- With the new **DirectSelect** control, you can set the desired power level and control such functions as the PerfectAir sensor, after-running, and lighting level directly

Cleaning:

- **Easy-to-clean interior** with hidden screws and cables along with rounded edges make cleaning easy
- Dishwasher-safe metal grease filters
- Electronic filter saturation indicator

Technology:

- Touch Control with lightline
- 3 power settings + 2 intensive settings with automatic revert
- Automatic run-on time 10 mins
- No. of metal grease filters 3
- Pipe outlet diameter (mm) 150/120

Dimensions:

- Dimensions exhaust air (HxWxD): 614-954 x 898 x 500 mm
- Dimensions recirculating (HxWxD): 614-1064 x 898 x 500 mm

Optional Accessories:

- DHZ1223: Chimney extension 1000 mm
- DHZ1233: Chimney extension 1500 mm
- DHZ5345: Recirculating kit
- DHZ5346: Active carbon filter
- DSZ5201: CleanAir active carbon filter spare part
- DSZ6240: CleanAir Recirculation Kit
- DWZ0XX0I5: Integrated CleanAir Recirculation Kit
- DWZ0XX0J5: Integrated CleanAir Recirculation Kit
- DZZ0XX0P0: CleanAir active carbon filter regenerative



DWB97LM50
Serie | 6
Stainless steel wall chimney,
90 cm

Key Highlights:

- 697 m³/h maximum extraction capacity
- **EcoSilence Drive**[®] brushless motor
- **Noise level** 55dB at minimum level (150mm ducted)
- **Energy Efficiency Class:** A

Convenience:

- **LED illumination:** The energy-saving lighting provides white and good lighting for the hob area
- **Automatic intensive revert** helps power automatically reverts back to normal setting after intensive speed setting

Cleaning:

- **Easy-to-clean interior** with hidden screws and cables along with rounded edges make cleaning easy
- Dishwasher-safe metal grease filters

Technology:

- Touch Control with LED display
- 3 power settings + 2 intensive settings with automatic revert
- Automatic run-on time 10mins
- No. of metal grease filters 3
- Pipe outlet diameter (mm) 150/120

Dimensions:

- Dimensions exhaust air (HxWxD): 614-954 x 898 x 500 mm
- Dimensions recirculating (HxWxD): 614-1064 x 898 x 500 mm

Optional Accessories:

- DHZ1223: Chimney extension 1000 mm,
- DHZ1233: Chimney extension 1500 mm,
- DHZ5345: Recirculating kit,
- DHZ5346: Active carbon filter,
- DSZ5201: CleanAir active carbon filter spare part,
- DSZ6240: CleanAir Recirculation Kit,
- DWZ0XX0I5: Integrated CleanAir Recirculation Kit,
- DWZ0XX0J5: Integrated CleanAir Recirculation Kit,
- DZZ0XX0P0: CleanAir active carbon filter Plus Recirc. Kit,
- DWZ2CX5C6: Clean Air Plus Recirculation Kit,
- DZZ0XX0P0: CleanAir active carbon filter regenerative
- DZZ1XX1B6: CleanAir plus active carbon filter



DWB67JP50
Serie | 6
Stainless steel wall chimney,
60 cm

Key Highlights:

- 657 m³/h maximum extraction capacity
- **EcoSilence Drive**[®] brushless motor
- **Noise level** 48dB at minimum level (150mm ducted)
- **Energy Efficiency Class:** A

Convenience:

- **LED illumination:** The energy-saving lighting provides white and good lighting for the hob area
- **Automatic intensive revert** helps power automatically reverts back to normal setting after intensive speed setting
- With the new **DirectSelect** control, you can set the desired power level and control such functions as the PerfectAir sensor, after-running, and lighting level directly

Cleaning:

- **Easy-to-clean interior** with hidden screws and cables along with rounded edges make cleaning easy
- Dishwasher-safe metal grease filters

Technology:

- Touch Control with lightline
- 3 power settings + 2 intensive settings with automatic revert
- Automatic run-on time 10mins
- No. of metal grease filters 2
- Pipe outlet diameter (mm) 150/120

Dimensions:

- Dimensions exhaust air (HxWxD): 614-954 x 598 x 500 mm
- Dimensions recirculating (HxWxD): 614-1064 x 598 x 500 mm

Optional Accessories:

- DHZ1225: Chimney extension 1000 mm
- DHZ1235: Chimney extension 1500 mm
- DHZ5345: Recirculating kit
- DHZ5346: Active carbon filter
- DSZ5201: CleanAir active carbon filter spare part
- DSZ6200: CleanAir Recirculation Kit
- DWZ0XX0I5: Integrated CleanAir Recirculation Kit
- DWZ0XX0J5: Integrated CleanAir Recirculation Kit
- DZZ0XX0P0: CleanAir active carbon filter regenerative
- HEZG9AS00S: Adapter



DIB98JQ50
Serie | 6
Stainless steel island chimney,
90 cm

Key Highlights:

- 867 m³/h maximum extraction capacity
- **High extraction rate** filters out over 85% of the grease from kitchen air
- **EcoSilence Drive**[®] brushless motor
- **Noise level** 54dB at minimum level (150mm ducted) with sound insulation mats
- **PerfectAir sensor** automatically detects cooking intensity and adjusts power level
- **Energy efficiency class:** A+

Convenience:

- **LED-illumination** the energy-saving lighting provides white and good lighting
- **Intensive speed setting** removes strong kitchen odours quickly and effectively
- **Automatic intensive revert** helps power automatically reverts back to normal setting after intensive speed setting
- With the new **DirectSelect** control, you can set the desired power level and control such functions as the PerfectAir sensor, after-running, and lighting level directly

Cleaning:

- **Easy-to-clean interior** with hidden screws and cables along with rounded edges make cleaning easy
- Dishwasher-safe metal grease filters

Technology:

- Touch Control with lightline
- Cooktop-based hood control ready
- 3 power settings + 2 intensive settings with automatic revert
- Automatic run-on time 10 mins
- No. of metal grease filters 3
- Pipe outlet diameter (mm) 150/120

Dimensions:

- Dimensions exhaust air (HxWxD): 744-924 x 898 x 600 mm
- Dimensions recirculating (HxWxD): 744-1044 x 898 x 600 mm

Optional Accessories:

- DHZ1231: Adapter for roof inclination left/right
- DHZ1241: Adapter for roof inclination front/back
- DHZ1246: Chimney extension 1100 mm
- DHZ1251: Extension for mounting kit 500 mm
- DHZ1253: Extension for mounting kit 1000 mm
- DHZ1256: Chimney extension 1600 mm
- DHZ5346: Active carbon filter
- DHZ5385: Recirculating kit
- DIZ2CX5C6: CleanAir plus Recirculation Kit
- DSZ5201: CleanAir active carbon filter spare part
- DSZ6230: CleanAir Recirculation Kit
- DZZ0XX0P0: CleanAir active carbon filter regenerative
- DZZ1XX1B6: CleanAir plus active carbon filter



Touch Control & DirectSelect:

- Set the exact power level with a single touch thanks to TouchControl and DirectSelect.
- Simply select the right power level or turn on the lights and away you go.
- With the new DirectSelect control, you can set the desired power level and control such functions as the PerfectAir sensor, after-running, and lighting level directly.



A+

DWK98PR60 Serie | 8 Clear glass black printed wall chimney, 90 cm

Key Highlights:

- 837 m³/h maximum extraction capacity
- **High extraction rate** filters out over 85% of the grease from kitchen air
- **EcoSilence Drive**® brushless motor
- **Noise level** 55dB at minimum level (150mm ducted) with sound insulation mats
- **Home Connect** app to remotely monitor/control the hood and its functions through your smartphone/Tab
- **PerfectAir sensor** automatically detects cooking intensity and adjusts level
- **Energy efficiency class:** A+

Convenience:

- **LED-illumination:** The energy-saving lighting provides white and good lighting
- **Clean air module** for maximum air purity at minimum volume
- Easy to install appliances give you another reason to choose a Bosch Hood
- **Automatic intensive revert** helps power automatically reverts back to normal setting after intensive speed setting
- Cooktop-based hood control ready
- With the new **DirectSelect** control, you can set the desired power level and control such functions as the PerfectAir sensor, after-running, and adjusting level directly

Cleaning:

- Dishwasher-safe metal grease filters

Technology:

- Touch Control with lightline
- Cooktop-based hood control ready
- 3 power settings + 2 intensive settings with automatic revert
- Automatic run-on time 10 mins
- Number of metal grease filter cassettes: 2
- Pipe outlet diameter (mm) 150/120

Dimensions:

- Dimensions exhaust air (HxWxD): 957-1227 x 894 x 548 mm
- Dimensions recirculating, chimney (HxWxD): 1017-1287 x 894 x 548 mm

Optional Accessories:

- DSZ5201: CleanAir active carbon filter spare part
- DWZ0AK0A0: Active carbon filter (spare part)
- DWZ0AK0R0: Recirculation kit regenerative chimless,
- DWZ0AK0S0: Recirculation kit regenerative
- DWZ0AK0T0: Recirculation kit for chimless use
- DWZ0AK0U0: Recirculation kit
- DWZ0AX5C0: CleanAir Recirculation Kit
- DWZ0AX5K0: Chimney extension 1000 mm
- DWZ0AX5L0: Chimney extension 1500 mm
- DWZ1AX5C6: CleanAir Plus Recirculation Kit
- DZZ0XX0P0: CleanAir active carbon filter regenerative
- DZZ1XX1B6: CleanAir plus active carbon filter

Technical Diagrams

All descriptions and technical diagrams are intended as a guide only. For additional technical information, full dimensional and installation details, please refer to the instruction and installation manuals supplied with the appliance. All measurements in mm.

DWB91PR50I

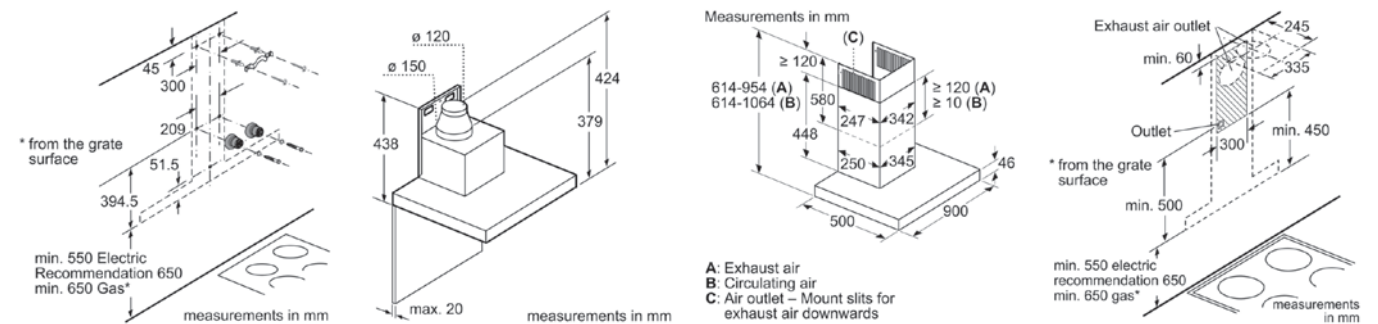

DWB98JR50I

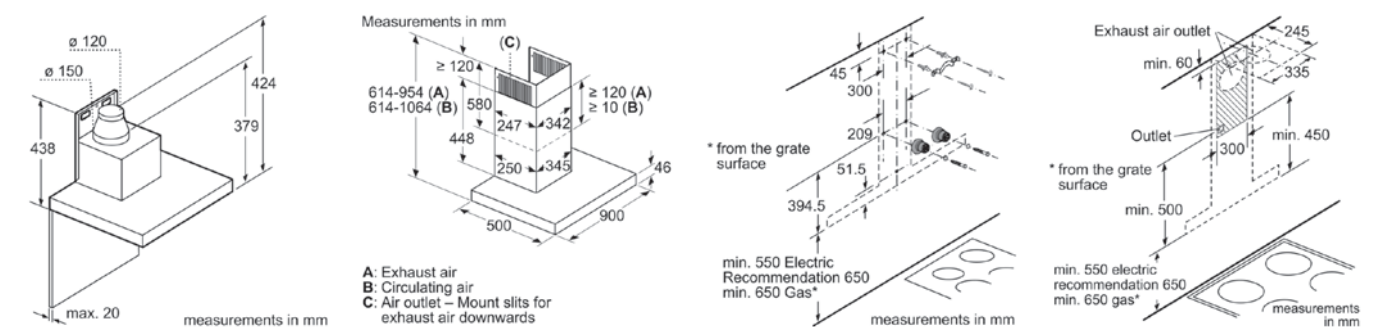

DWB97LM50I

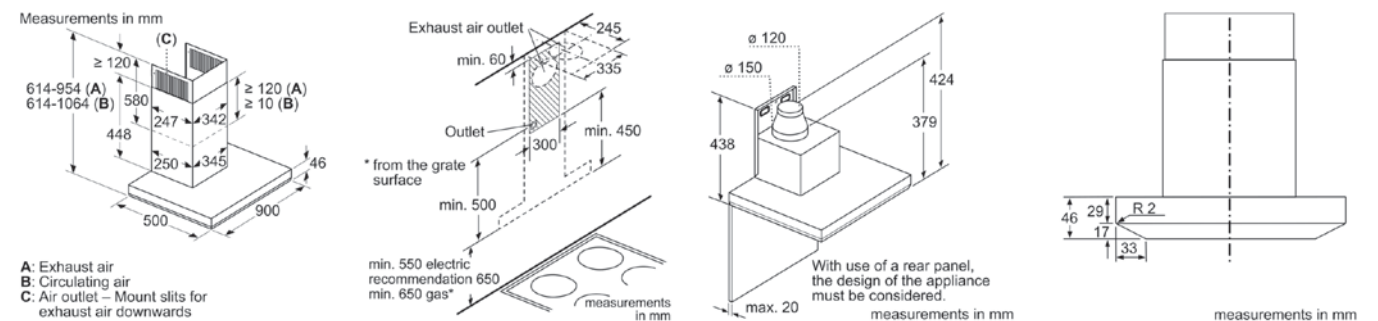

DWB67JP50I

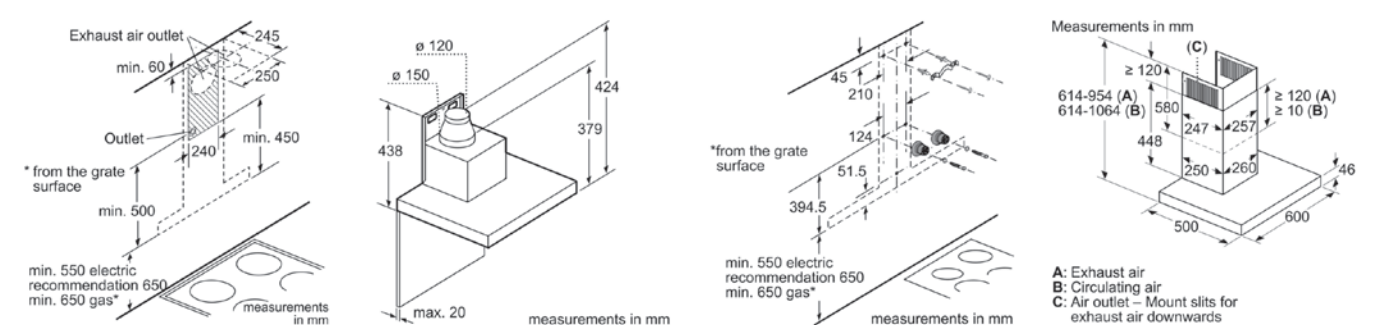

Intensive / Automatic intensive revert:

- For fast and effective extraction, the intensive speed setting removes strong kitchen odours quickly and effectively.
- Power automatically reverts back to normal setting after intensive revert.
- When there's a power cut, or if you have to move out, just pause and the chimney gets activated automatically with preset settings as you start cooking.

Technical Diagrams

All descriptions and technical diagrams are intended as a guide only. For additional technical information, full dimensional and installation details, please refer to the instruction and installation manuals supplied with the appliance. All measurements in mm.

DIB98JQ50I

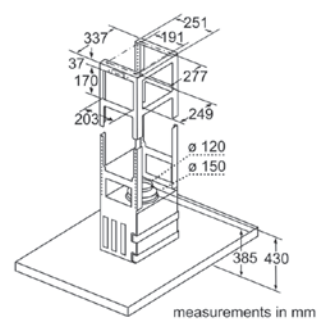
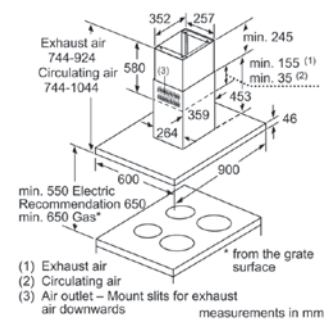
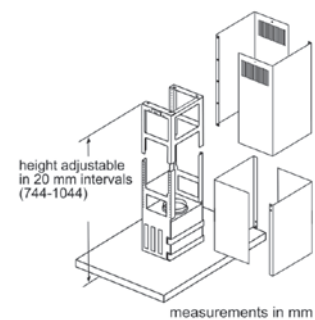

DWK98PR60I

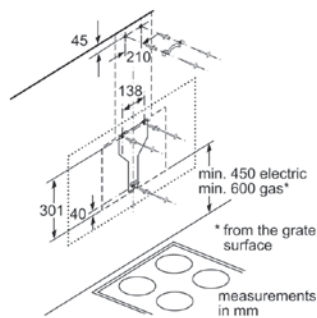
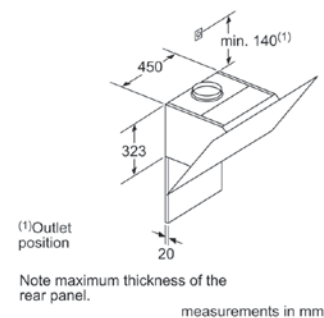
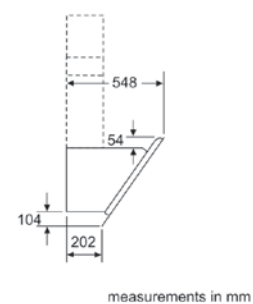
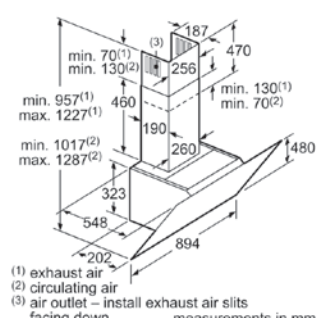
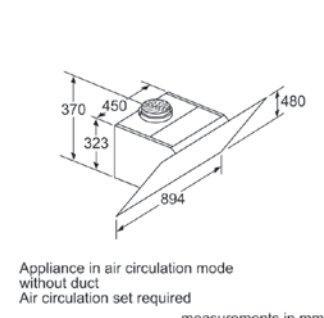
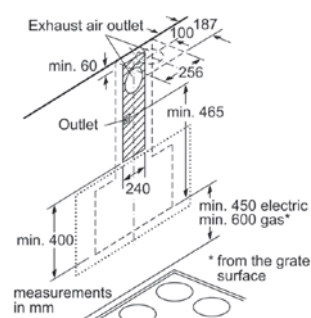

Ovens & Microwaves





Like an imaginary friend who in real cooks, bakes, roasts and cleans for us.

Bosch microwaves and ovens, like a true friend, have you covered in the kitchen to ensure you achieve perfection when it comes to baking, cooking, grilling, and roasting your food. P.S it can clean itself too.



Key Innovations

Specific features vary by model



PerfectBake: With the built-in PerfectBake™ sensor, Bosch Ovens make perfect baking a reality. It measures the moisture content of your dish with precision and automatically adjusts the baking process, right from the heating mode, length of cooking time to temperature, and bakes your cake to perfection.



PerfectRoast: The use of highly sensitive points allow Bosch ovens to determine the core temperature of your food to the exact degree, guaranteeing perfect roasting results.



BoschAssist: A feature that not only automatically sets the ideal amount of heat, temperature, and time for numerous dishes but also assists you like a co-chef in the kitchen. Plus, you can also learn about our intuitive baking and roasting functions.



Pyrolysis: The integrated self-cleaning function Pyrolysis turns grease or residue in the oven to dust by heating up to 480 degrees. So, you can eat away at ease whilst the oven cleans itself by itself.



Home Connect^: Turn your appliance on and off from anywhere, with the Easy Monitoring feature. Get your oven ready to use, when you are ready to cook with Remote Preheat. And for the times you get late at work or lose track of time before a party, simply delay your cooking on command with Remote Delayed Start. What's more, you can access the World of Recipes to discover healthy, delicious recipes and send the appropriate settings straight to your oven. We've also taken care of your child's safety with the Safe & Sound feature, so you can focus on bonding over baking with them.



HSG636BB1
Serie | 8
Steam convection built-in oven,
Black

Key Highlights:

- **The 60cm high steam oven** perfect baking, moist steam baking and gentle steaming
- **4D Hot Air** for even heat distribution for perfect results on any level
- **Full steam** with the Series 8 steam oven you can prepare an entire meal on up to three levels at once – for example, cook salmon, asparagus and rosemary potatoes simultaneously. The humidity prevents flavours from intermingling so that each dish retains its own authentic flavour
- **TFT Touch display** easy to use thanks to the clear text display and images
- **BoschAssist** for automatic setting of the optimal type heat, temperature and time for countless dishes
- **Flap door with SoftOpen and SoftClose function** enables the oven door to open and close gently and quietly
- Energy efficiency class : A+

Convenience:

- Cavity Volume: 71 Lts
- Bottom heat and Conventional heat
- Combi-steam oven with 12 heating methods
- Additional heating methods like Reheating, dough proving, defrost
- Fermentation
- Full width broil and Half width broil
- Hot air broiling and Hot Air-Eco
- Low temperature cooking
- Other functions like pizza setting and pre-heating
- Child-proof Lock
- Tank empty indicator
- Descaling programme
- Automatic boiling point detection
- Drying function
- Rapid Heating-up: automatic
- Electronic function: Sabbath setting
- Actual temperature display

Cleaning:

- **EcoClean Direct:** The energy-saving cleaning aid, makes oven cleaning easy with no cleaning effort thanks to a special coating of microfine ceramic spheres on the interior oven walls that breaks down grease spatters while you bake or roast.

Technical:

- Additional heating methods like Reheating, dough proving, defrost
- Total connected load 3600 W
- Cable length: 120 cm
- Temperature range 30°C - 250°C

Dimensions:

- Overall appliance dimension (HxWxD): 595 x 594 x 548 mm
- Cut out dimension (HxWxD): 585-595 x 560-568 x 550 mm

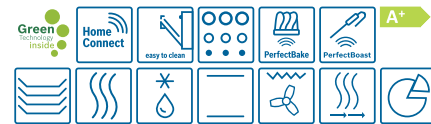

HBG6764B6B
Serie | 8
Single wall oven,
Black

Key Highlights:

- **PerfectBake sensor and PerfectRoast thermometer** provide the easy way to perfect baking and roasting results.
- **4D Hot Air** for even heat distribution for perfect results on any level
- **TFT touchscreen control** easy-to-use thanks to the control ring with full text and images
- **BoschAssist** for automatic setting of the optimal type of heat, temperature and time for countless dishes
- **Home Connect** app allows you to stay on top of your game by giving you easy access to a wide variety of innovative cooking and meal preparation techniques all from the comfort of your mobile device
- **Flap door with SoftOpen and SoftClose function** enables the oven door to open and close gently and quietly
- Energy efficiency class : A+

Convenience:

- Cavity Volume: 71 Lts
- Bottom heat and Conventional heat
- Oven with 13 heating methods
- Defrost
- Full width broil and half width broil
- Hot air broiling and Hot Air-Eco
- Low temperature cooking
- Other functions like pizza setting and pre-heating
- Rapid heating-up: automatic
- Electronic clock with LED display
- Integral cooling fan

Cleaning:

- With **Pyrolysis Cleaning** process cleaning is carried out automatically without the use of chemical cleaning products.

Technical:

- Total connected load 3450 W
- Cable length: 120cm
- Temperature range 30°C - 300°C

Dimensions:

- Overall appliance dimensions (HxWxD): 595 x 594 x 548 mm
- Cut out dimensions (HxWxD): 585-595 x 560-568 x 550 mm

Included Accessories:

- 1 x combination grid, 1 x universal pan

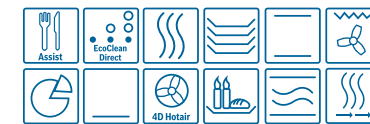

CMG636BB21
Serie | 8
Built-in compact oven with microwave
with timer, Black

Key Features:

- **The built-in oven with top-/bottom heat** achieve perfect results on one level thanks to optimal distribution of heat
- **Intelligent Inverter Technology** delivers maximum output power regulated to 600 W when used in longer operation
- **4D Hot Air** for even heat distribution giving perfect results on any level
- **Convection Cooking** delivers oven-like results
- **Microwave function** for quick warming up or for fast cooking in combination with hot air.
- **TFT touchscreen control** easy-to-use thanks to the control ring with full text and images
- **BoschAssist** for automatic setting of the optimal type of heat, temperature and time for countless dishes
- **Flap door with SoftOpen and SoftClose function** enables the oven door to open and close gently and quietly
- Energy efficiency class : A+

Convenience:

- Cavity Volume: 45 Lts
- Bottom heat and conventional heat
- Combi microwave variable
- Full width broil and half width broil
- Hot air broiling and Hot Air-Eco
- Other functions like pizza setting and pre-heating warming functions
- Heat reflective glass
- Black glass front as a brilliant alternative to stainless steel
- Child-proof lock, Automatic Switch on/off, Residual Heat Indicator
- Electronic clock with LED display

Cleaning:

- **EcoClean Direct:** The energy-saving cleaning aid, makes oven cleaning easy with no cleaning effort thanks to a special coating of microfine ceramic spheres on the interior oven walls that breaks down grease spatters while you bake or roast.
- Enameled interiors for better cleaning.

Technical:

- Max. Power: 900 W
- Nominal voltage: 220 - 240 V
- Additional heating methods with microwave: microwave, combi microwave variable Reheating, dough proving, defrost
- Total connected load 3600 W
- Cable length: 150 cm

Dimensions:

- Overall appliance dimensions (HxWxD): 455 x 594 x 548 mm
- Cut out dimension (HxWxD): 450-455 x 560-568 x 550 mm



BFL634GB11
Serie | 8
Built-in microwave oven,
Black

Key Highlights:

- The built-in microwave for the 38 cm niche: use it for thawing, heating and faster preparation of foods
- **Intelligent Inverter Technology** delivers maximum output power regulated to 600 W when used in longer operation
- **AutoPilot 7** every dish is a perfect success thanks to 7 pre-set automatic programs
- **TFT touchscreen control** easy-to-use thanks to the control ring with full text and images
- Energy efficiency class : A+

Convenience:

- Cavity Volume: 21 Lts
- 3 defrost and 4 cooking programs in microwave function

Cleaning:

- **Stainless steel interior with glass bottom** is easy to clean interior thanks to smooth surfaces and no sharp edges

Technical:

- Max. Power: 900 W; 5 Microwave power settings: 90 W, 180 W, 360 W, 600 W, 900 W
- Total connected load 1220 W
- Cable length: 150 cm

Dimensions:

- Overall appliance dimension (HxWxD): 382 x 594 x 318 mm
- Cut out dimensions (HxWxD): 362-380 x 560-568 x 300 mm



Even Heat, Maximum Flexibility:

- Place your food on any of the four shelf levels and the results will be consistent
- Our motor and fan wheel design makes it possible: it changes the direction of rotation during operation to distribute heat evenly on every level.
- With 4D HotAir, you can also bake and roast on up to four different levels simultaneously. So you'll enjoy reliable results from top to bottom



TFT Touchscreen control:

- Easy-to-use thanks to the intuitive control ring with full text and images.
- With a small turn of the center ring, you can adjust any of your oven's settings with just one finger
- The TFT-display also aids the process by providing clear text and directly selectable buttons.

Technical Diagrams

All descriptions and technical diagrams are intended as a guide only. For additional technical information, full dimensional and installation details, please refer to the instruction and installation manuals supplied with the appliance. All measurements in mm.

HSG636BB1

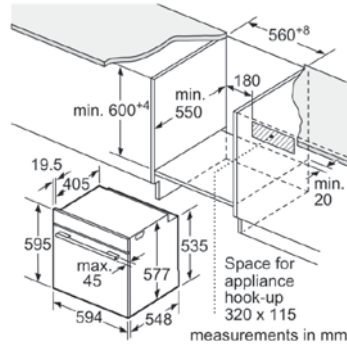
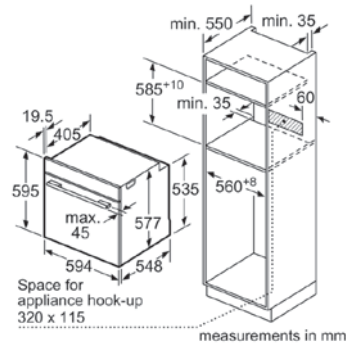

If the appliance is installed beneath a cooktop, the following countertop thickness (possibly incl. substructure) must be observed.

Cooktop type	min. countertop thickness	
	fitted	flush
Induction cooktop	37 mm	38 mm
Full-surface induction cooktop	47 mm	48 mm
Gas cooktop	30 mm	38 mm
Electric cooktop	27 mm	30 mm

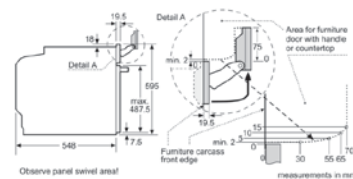

HBG6764B6B

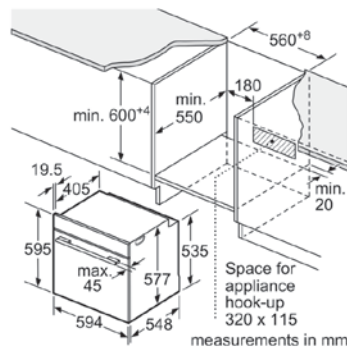
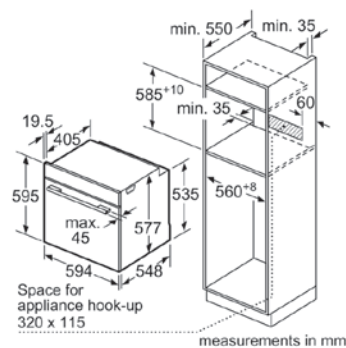

If the appliance is installed beneath a cooktop, the following countertop thickness (possibly incl. substructure) must be observed.

Cooktop type	min. countertop thickness	
	fitted	flush
Induction cooktop	37 mm	38 mm
Full-surface induction cooktop	47 mm	48 mm
Gas cooktop	30 mm	38 mm
Electric cooktop	27 mm	30 mm

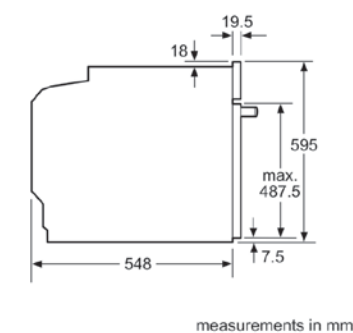

CMG636BB2I

Installation with a cooktop.

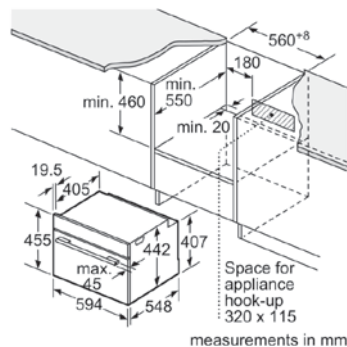
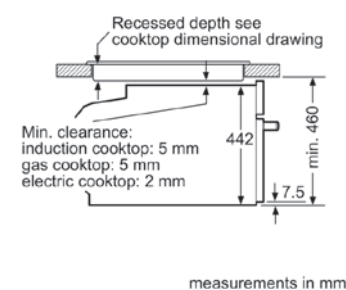

If the compact appliance is installed beneath a cooktop, the following countertop thickness (possibly incl. substructure) must be observed.

Cooktop type	min. countertop thickness	
	fitted	flush
Induction cooktop	42 mm	43 mm
Full-surface induction cooktop	52 mm	53 mm
Gas cooktop	32 mm	43 mm
Electric cooktop	32 mm	35 mm

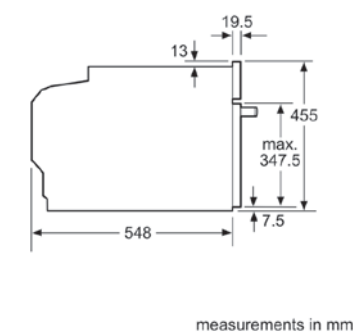

BFL634GB1I

Measurements in mm

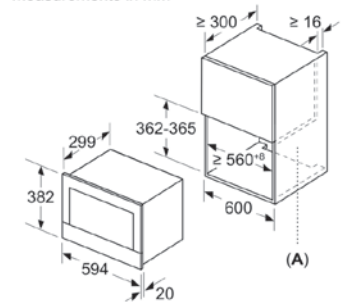

Measurements in mm

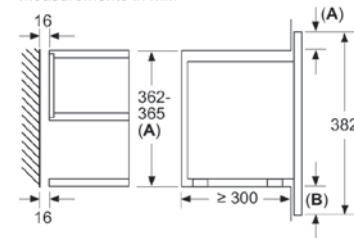

A: Overhang at top:
Niche 362: 6 mm
Niche 365: 3 mm
B: Overhang at bottom: 14 mm

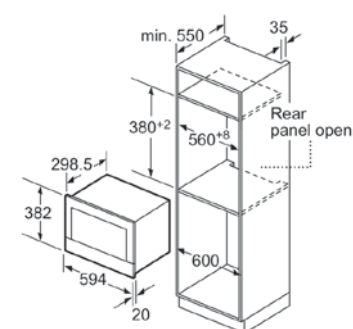

Warming Drawer

Even the last person to eat, gets a warm meal.

Warmer Drawers don't just keep your food warm, but they also open up a world of possibilities, like pre-warming tableware, thawing delicate foods and proofing yeast dough.

Key Innovations

Specific features vary by model

The multi-functional warming drawer for the 14 cm niche: For pre-heating plates and keeping food warm. This multi-functional Series 8 Warming Drawer fits a 14cm niche and provides that additional kitchen convenience, you didn't know you needed.

Push-pull mechanism: The spring enabled push-pull mechanism makes the drawer smooth and effortless to open and close. With its sleek facade and stunning stainless steel craftsmanship, it truly is a beautiful component to add to your kitchen.

Keeping drinks and food warm: There are four temperature levels between 40°C - 80°C, ideal for pre-warming crockery, keeping drinks and food warm and gently defrosting delicate food items.



Picture is for representation purpose only.



BIC510NB0
Serie | 6
Warming drawer,
14 cm, Black

Key highlights:

- Cavity volume: 23 Lts
- 4 Functions: keeping drinks and food warm, pre-warming of tableware, yeast dough proofing, thawing of delicate foods
- Keeps food warm for hours while retaining freshness and flavor.
- Auto shut off, keep warm settings and humidity controls to maintain freshness of food at turn of a knob.
- Can accommodate up to 14 plates or 64 espresso cups
- Loading up to 15 kg

Dimensions:

- Appliance Dimension (H x W x D):
140 x 594 x 540 mm
- Cut out Dimension (H x W x D):
14 x 56.8 x 55 cm

Technical Diagrams

All descriptions and technical diagrams are intended as a guide only. For additional technical information, full dimensional and installation details, please refer to the instruction and installation manuals supplied with the appliance. All measurements in mm.

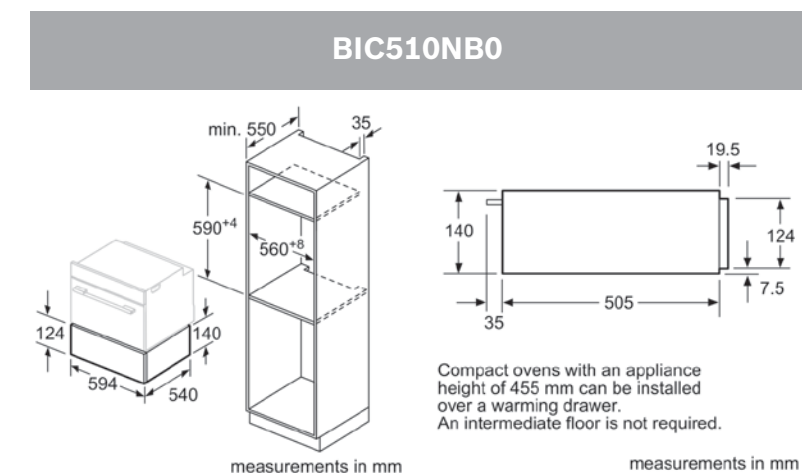

Coffee Machine

CONNECTED BY
Home Connect





Like your personal butler that intuitively knows your favorite brews.

Our built-in coffee centre comes enabled with Home Connect, to offer you not just unparalleled convenience but unparalleled variety too.

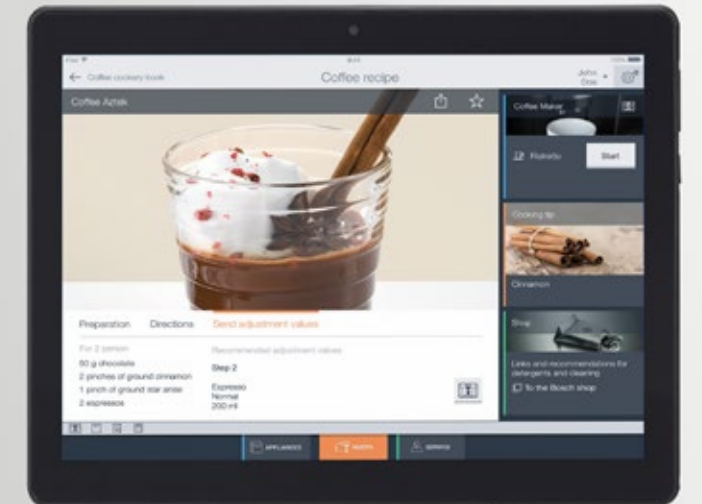

Key Innovations

Specific features vary by model



Intelligent heater: You'll never have to wait for that perfect cup of coffee again. Get that dreamy aroma and taste, whenever you want. The SensoFlow System controls the temperature to perfection so you get, nothing but the most aromatic coffee every single time.



OneTouch DoubleCup: Get used to having the finest coffee ready, at the push of a button. Whether it's one cup or two, you can enjoy your preferred espresso or milk beverage, almost instantly.



AromaDouble Shot: What's more divine than a single shot of espresso? A delicious double shot. Experience the kick of that extra-strong coffee without the bitterness thanks to dual grinding and brewing processes. This pours double the amount of coffee simultaneously, so you get maximum flavour, minimum bitterness.



AutoMilk Clean: A state-of-the-art system that steam cleans itself after preparing every drink, ensuring the highest standards of hygiene for you.



Home Connect*: Master the art of relaxation and let your coffee centre do all the work. Sit back and Remote Start your machine through the app. Program customised drinks for your guests with the CoffeePlaylist. Dive into the CoffeeWorld and explore 17 coffee specialities from across the globe. Experiment with beverages with the Coffee Recipe feature on the app. And last but not the least, dazzle your guests by becoming a coffee expert with Coffee Know Hows.

*Please note that this service is only available in English and for the appliances installed in cities - Mumbai, Delhi NCR, Bangalore, Kolkata, Hyderabad, Chennai, Ahmedabad, Pune and Jaipur. For further information please check: www.home-connect.co.in or contact BSH Household Appliances Mfg. Pvt. Ltd. @ service.in@bosch-home.com



CTL636ES6
Serie | 8
Built-in coffee machine,
Stainless steel

Flavour:

- **SensoFlow System:** The innovative heating system guarantees maximum espresso indulgence every time, thanks to its ideal, constant brewing temperature
- **One-touch preparation:** Ristretto, Espresso, Espresso Macchiato, Coffee, Cappuccino, Latte Macchiato, Caffè Latte at the touch of a button
- **AromaDouble Shot:** Extra-strong coffee with less bitterness thanks to two grinding and brewing processes
- **Beverage temperature adjustable individually:** coffee 3 levels, hot water 4 levels
- **Suitable for BRITA Intenza water filter:** Reduces the lime content of water and filters substances affecting smell and taste
- **Home Connect** app gives you a relaxation and makes the coffee centre to do all the work. Just remote start and enjoy the customized drinks with the CoffeePlaylist

Convenience:

- Colour TFT display with interactive menu
- MyCoffee: Save 8 favourite beverages with individual names and adjustable mixing ratio of milk and espresso
- IndividualCup Volume: Cup sizes adjustable individually
- Coffee outlet and milk frotherheight-adjustable: Up to 15 cm high Latte Macchiato glasses fit underneath
- Get two cups of any coffee or milk speciality at the touch of a button with oneTouch DoubleCup.
- Water tank removable for easy refilling (2.4 l volume)

Performance:

- SilentCeram Drive: Quiet premium grinder made from nonwearing ceramic
- CoffeeSensor Pro: The grinding unit automatically adjusts to bean variety
- All coffee and milk beverages are prepared at the touch of a button with the oneTouch Function.
- In addition to beverages also available separately: milk foam, warm milk, hot water
- Reduced heat-up time: Fast first cup
- Water pump with 19 bar pressure

Hygiene:

- Removable brewing unit: Easy and hygienic cleaning under running water
- Automatic steam cleaning after every drink with autoMilk Clean.
- Milk frother removable and dishwasher-proof
- Drip tray and coffee grounds container removable and dishwasher-proof
- Calc'nClean: Automatic cleaning and descaling programme
- Reminds in time of water filter change, descaling, cleaning

Accessories:

- Insulatedmilk container with FreshLock lid (0.5 l volume)
- Further included accessories: connection hose for milk frother, test strip for water hardness, assembly screws
- Separately available accessories: cleaning tablets (TCZ8001...), descaling tablets (TCZ8002...), BRITA Intenza water filter (TCZ7003/TCZ7033), care set for fully-automatic espresso makers (TCZ8004...), insulated milk container (TCZ8009N)



Finely ground for a perfect flavour:
CeramDrive.:

- The exceptionally high-quality and durable grinder made from non-wearing ceramic grinds your coffee consistently fine, allowing the full flavour of every single bean to develop. The degree of grinding can be adjusted individually—resulting in a better taste and incomparable flavor

Technical Diagrams

All descriptions and technical diagrams are intended as a guide only. For additional technical information, full dimensional and installation details, please refer to the instruction and installation manuals supplied with the appliance. All measurements in mm.

CTL636ES6

corner installation left

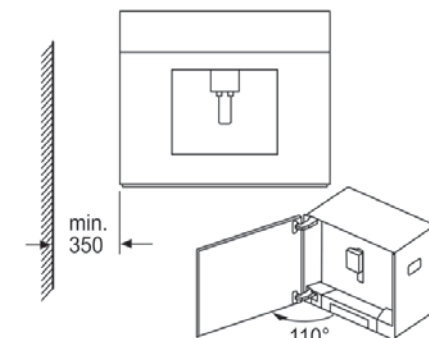

When using the 92° hinge limiter (Spare part no. 00636455) the minimum clearance from the wall is only 100 mm. measurements in mm

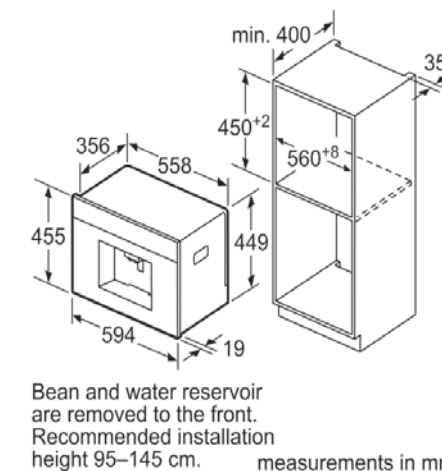
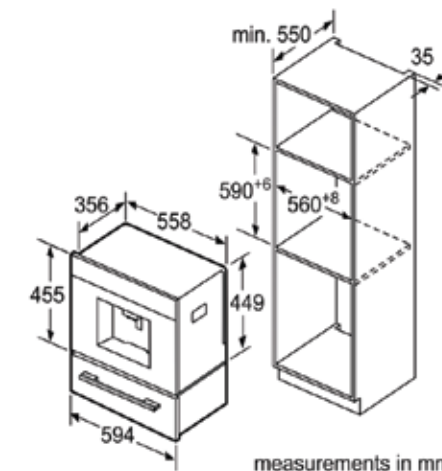

Bean and water reservoir are removed to the front. Recommended installation height 95–145 cm. measurements in mm

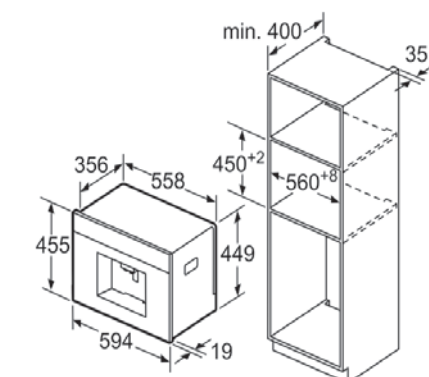

Bean and water reservoir are removed to the front. Recommended installation height 95–145 cm. measurements in mm

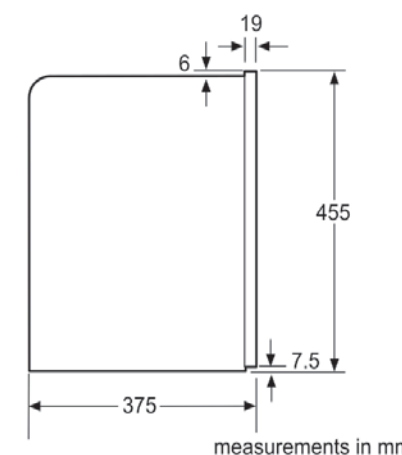

measurements in mm



Refrigerator



Match your refrigerator to your style.

The new aesthetically appealing Bosch refrigerators give you a fresh look from the outside while keeping your food fresh on the inside. Choose from Graphite, Glass or Vario style refrigerators to redesign your kitchen the way you desire.



Picture is for representation purpose only.

Key Innovations

Specific features vary by model



VarioStyle door: With the new Vario Style bottom freezer, simply change the colour of your fridge to match your style. Enabled by a clever combination of invisible hooks and magnets, this surprisingly simple solution provides you a great variety of high quality colour door fronts. Enjoy an individual fresh look; from vibrant red cherry to bold colours, like espresso brown, passing through seasonable nature colours such as aqua.



Home Connect⁺: Operate fridge setting through your smartphone wherever you want and whenever you want. Set multiple functions like - Temperature setting, holiday mode, super cool/freeze.



Camera in the Fridge: The cameras in the fridge take a snapshot of its contents, so you can find out what ingredients you're missing while out shopping for groceries.



VitaFresh: Your food will feel and stay as fresh as the day you bought it, thanks to the VitaFresh system. It balances the humidity of the fruits and vegetable compartment and keeps them fresh. And it even retains their original flavour, texture, and appearance so that you have fresh-tasting food every day.



MultiAirflow: It improves overall air circulation, regulates the temperature, and eliminates the possibilities of condensation in the fridge.



SuperCooling: No more waiting for long to cool your drinks. Super Cooling cools your fridge/ freezer's temperature faster and when it's done, the compressor switches off automatically.



SuperFreezing: If you run out of ice, you won't have to wait for the next batch to be ready. Super freezing speeds up the process of making ice.

*Please note that this service is only available in English and for the appliances installed in cities - Mumbai, Delhi NCR, Bangalore, Kolkata, Hyderabad, Chennai, Ahmedabad, Pune and Jaipur. For further information please check: www.home-Connect.co.in or contact BSH Household Appliances Mfg. Pvt. Ltd. @ service.in@bosch-home.com





KAD92HBFP
Serie | 8
Side by side
black glass

Key Highlights:

- Gross capacity: 636L
- Camera inside fridge to check fridge content wherever you are and whenever you want
- Home connect app to remotely access your fridge and change temperature settings
- Ice water dispenser
- MultiAirflow
- SuperFreezing & SuperCooling
- VitaFresh Plus for fresh fruits & vegetables
- Inverter Compressor with temperature sensors
- Store Management tips to ideally store your food inside fridge

Fridge Compartment:

- Multi Airflow-System
- 4 safety glass shelves of which 3 are height adjustable
- 2 door trays high

Freezer Section:

- Freezing capacity: 12 kg/24 h
- Storage time in power failure: 12 h
- 2 transparent freezer drawers
- 4 door trays in the freezing compartment

Technical Information:

- Energy Efficiency Class: A++
- Energy consumption: 348 kWh/yr
- Noise level: 42 dB
- Dimension (HxWxD): 177.8 x 91.2 x 73.2 cm

Included accessories:

- 2 x cold accumulator, 1 x connection hose, 1 x egg tray



KFN96PX91I
Seire | 8
French door bottom mount
graphite

Key Highlights:

- Gross capacity: 612L
- Notification on phone if door kept open for longer duration
- Dual Inverter compressor
- 3 tier layered freezer drawer for better organization and store more frozen food
- MultiAirflow
- SuperFreezing & SuperCooling
- VitaFresh Pro for 3 times longer fresh fruits and vegetables

Fridge Compartment:

- 2 vegetable containers
- 2 zero degree containers
- 6 Safety Glass Shelves of which 5 are height adjustable
- 2 door trays (Large)
- 3 door trays (Small)
- 1 door tray with flap

Freezer Section:

- 3 Drawers
- 1 Big box
- Freezing Capacity: 18 kg/ 24h

Technical Information:

- Noise level (dB): 39 dB
- Dimension (HxWxD): 183.0 x 90.6 x 71.0 cm

Included accessories:

- 1 egg tray

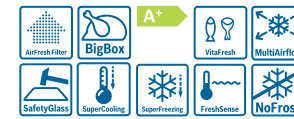

KFN86AA66I
Seire | 6
French door bottom mount
rosy brown glass door

Key Highlights:

- Gross capacity: 549L
- Notification on phone if door kept open for longer duration
- Inverter compressor with temperature sensor
- True counter-depth to provide built-in look & feel
- MultiAirflow
- SuperFreezing & SuperCooling
- VitaFresh Pro for 3 times longer fresh fruits and vegetables

Fridge Compartment:

- 2 vegetable containers
- 2 zero degree containers
- 3 Safety Glass Shelves of which 2 are height adjustable
- 2 door trays (Large)
- 3 door trays (Small)
- 1 door tray with flap

Freezer Section:

- 4 Drawers
- 2 Big box
- Freezing Capacity: 7 kg/ 12h

Technical Information:

- Noise level (dB): 35 dB
- Dimension (HxWxD): 183.0 x 81.1 x 73.6cm

Included accessories:

- 1 egg tray



KIN86AF30I
Seire | 6
Built-in bottom freezer

Key Highlights:

- Gross capacity: 273L
- Power ventilation for uniform air circulation
- Inverter compressor with temperature sensor
- 3 tier layered freezer drawer for better organization and store more frozen food
- MultiAirflow
- SuperFreezing & SuperCooling
- VitaFresh Plus for fresh fruits & vegetables

Fridge Compartment:

- 1 VitaFresh plus drawer keeps fruits and vegetables fresh for up to 2 times longer.
- 5 Safety Glass Shelves of which 4 are height adjustable
- 1 door shelf large, 3 door shelf small
- 1 Dairy compartment

Freezer Section:

- 3 Pull-out drawers for storage, including 1 Big Box for storing large items
- Freezing capacity: 8 kg/24 h

Technical Information:

- Noise level (dB): 38 dB
- Dimension (HxWxD): 177.2 x 55.8 x 54.5cm

Included accessories:

- 2 x cold accumulator, 2 x egg tray, 1 x ice cube tray



KGN391J4I
Seire | 4
VarioStyle bottom freezer

Key Highlights:

- Gross capacity: 400L
- VarioStyle: Change door to provide new fresh kitchen aesthetics
- Inverter compressor with temperature sensor
- 3 tier layered freezer drawer for better organization and store more frozen food
- MultiAirflow
- SuperFreezing & SuperCooling
- VitaFresh for fresh fruits & vegetables

Fridge Compartment:

- 1 VitaFresh drawer with humidity control
- 5 Safety Glass Shelves of which 3 are height adjustable
- 1 door tray (Large)
- 3 door trays (Small)
- 1 bottle grid
- 2 Chillers

Freezer Section:

- 2 Freezer Safety Glass Shelves
- 3 Drawers

Technical Information:

- Noise level (dB): 39 dB
- Dimension (HxWxD): 203.0 x 60 x 66.0cm

Included accessories:

- 3 x egg tray, 1 x ice cube tray with lid



KSZ1BVO00
Orange



KSZ1BVH00
Lime green



KSZ1BVE00
Raspberry



KSZ1BVJ00
Mint green



KSZ1BVU00
Aqua



KSZ1BVX00
Pearl gold



KSZ1BVU10
Petrol



KSZ1BVN00
Night blue



KSZ1BVG20
Pearl anthrazite



KSZ1BVR00
Cherry red



KSZ1BVD00
Espresso brown



VarioStyle door:

With the new Vario Style bottom freezer, simply change the colour of your fridge to match your style. Enabled by a clever combination of invisible hooks and magnets, this surprisingly simple solution provides you a great variety of high quality colour door fronts. Enjoy an individual fresh look; from vibrant red cherry to bold colours, like espresso brown, passing through seasonable nature colours such as aqua. With the Vario Style bottom freezer featuring VitaFresh system, not only your food will stay fresher for longer, but your fridge will also look fresh anytime.

Technical Diagrams

All descriptions and technical diagrams are intended as a guide only. For additional technical information, full dimensional and installation details, please refer to the instruction and installation manuals supplied with the appliance. All measurements in mm.

KAD92HBFP

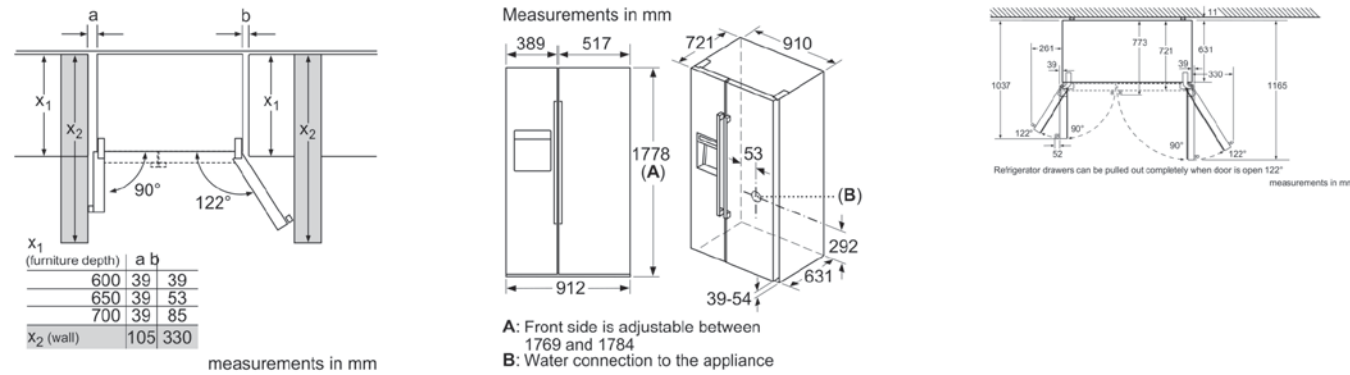

KIN86AF30I

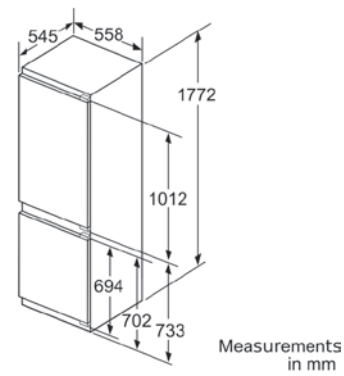
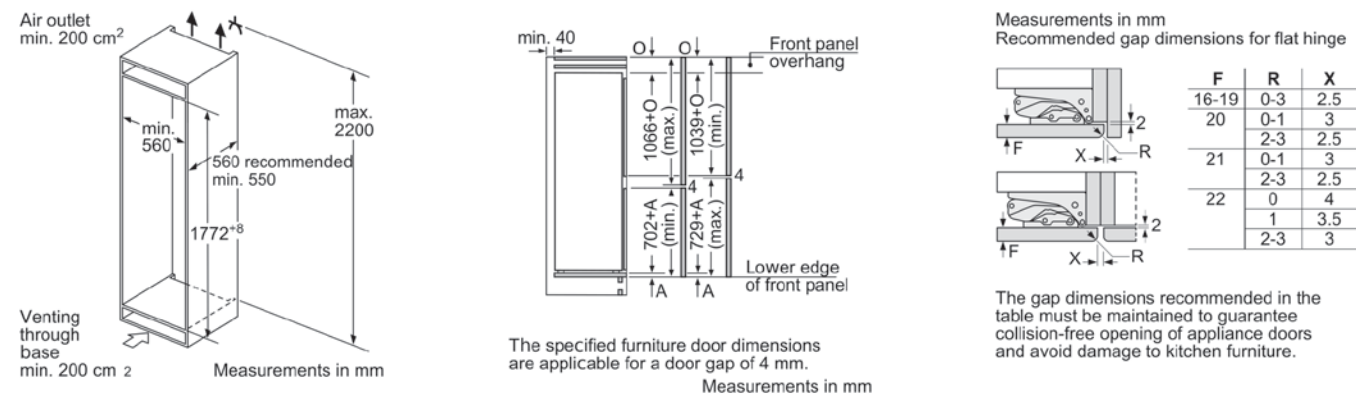

KGN39IJ4I

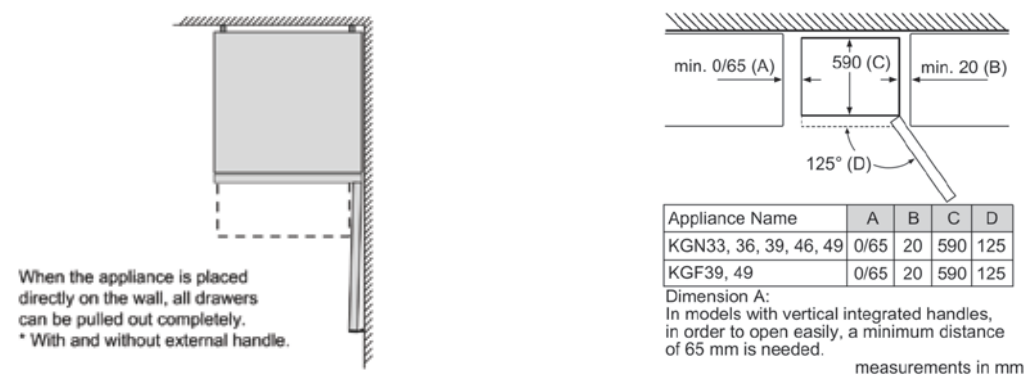

Picture is for representation purpose only.

Dishwasher



Let your amazing cooking stories have a happy ending.

After spending enough time cooking, Bosch Dishwashers ensure that you spend the rest of your time comfortably. Enjoy those post-meal moments with your loved ones, than have to worry on spending your time cleaning those tough masala and oily stains, off your Indian utensils. Perfectly programmed to pre-rinse, wash and dry, your Bosch dishwashers give you sparkling and hygienic utensils, ready for use within no time.



Picture is for representation purpose only.

Key Innovations

Specific features vary by model



PerfectDry - Zeolith® Patented Drying Technology: A unique, energy-efficient function that produces ready-to-use utensils by harnessing the power of Zeolith® technology resulting in a better drying performance and less electricity consumption.



Home Connect: The IOT enabled remote-access ecosystem lets you connect directly with your dishwasher from anywhere, through the Home Connect^ App. Now you can control everything remotely.



RackMatic basket: The 3-Stage RackMatic flexible basket fits almost everything your kitchen has to offer. By pushing a simple clip on the upper basket, you can adjust it's height at 3 levels vertically to accommodate Indian utensils of different sizes.



OpenAssist: The OpenAssist technology of Bosch in fully integrated dishwashers makes the door opening very easy. Simply, light press the door and it opens effortlessly. Such is the ease that it seamlessly blends in to the world of handle-free kitchen.



Extra Clean Zone: Three rotating water nozzles delivers extra soaking and cleanses your top racks items thoroughly. Simply press to activate and leave your dishwasher to deliver perfect results.



Time Light Projection: Time Light is pivotal among these everyday clarifiers, it projects the remaining time as well as the ongoing process of the programme on any type of kitchen floor.



AquaStop® Plus: AquaStop® Plus detects leaks in the solid molded base of the dishwasher, shuts down operation and automatically pumps out water so it cannot make contact with the floor.



Made in Germany, Made for You: For the longest time, washing utensils has been one of the tedious chores in an Indian household and Bosch Dishwashers has simply redefined that with the cutting edge innovation and German precision combined together, expect greasy and oily utensils to be spick and span in no time.

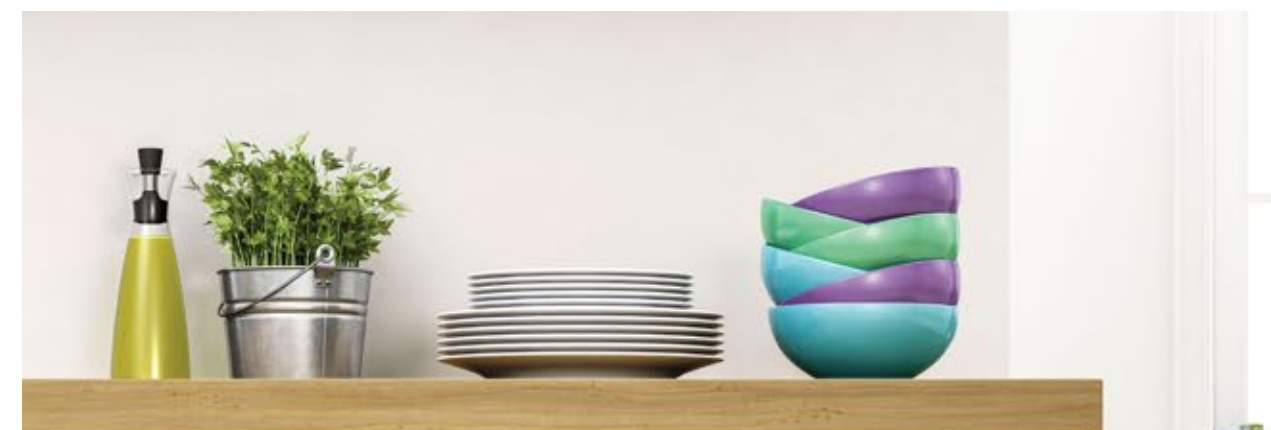



SMD6ZCX50E

Fully integrated,
14 place settings

Key Highlights:

- PerfectDry – Patented Zeolith® Drying technology
- Home Connect – IOT Enabled Dishwasher
- 3 Stage Rackmatic Flexible basket
- OpenAssist
- Extra Clean Zone
- Time Light Projection
- Made in Germany

Design & Innovation:

- Touch Panel
- Downloadable Programme*
- Remote Diagnostic*
- Additional Cutlery Drawer
- Glass care protection system for delicate crockery & glassware.
- Silent wash with eco silence drive
- 6x flip tines in the Upper basket
- 8x flip tines in the bottom basket
- Stainless steel tub
- DosageAssist
- Inbuilt Water softener
- Machine care
- AquaSensor, LoadSensor
- AquaStop plus leak protection
- Detergent Automation

Programmes:

- **8 programmes:** Intensive 70°C, Auto 45-65°C, Eco 50°C, Express 60°C, Glass, Silence, Express 45°C, Custom programme
- **5 special options:** ExtraDry, IntensiveZone, SpeedPerfect Plus, Machine care, Remote Start

Technical information:

- Energy efficiency class: A+++
- Energy consumption: 0.83 kWh
- Water consumption: 9.5 liters
- Noise level: 42 dB
- Appliance dimensions (HxWxD): 81.5cm x 59.8cm x 55.0cm



SMI4HCS48E

Semi integrated,
14 place settings

Key Highlights:

- Home Connect (IOT Enabled Dishwasher)
- Integration with: Google / Alexa voice assistance, IFTTT, Fitbit/Apple/Android smart watches, etc.
- 3 Stage Rackmatic Flexible Basket
- Silent wash with EcoSilence Drive
- DosageAssist
- Made In Germany

Design & Innovation:

- Downloadable Programme*
- Remote Diagnostic*
- Additional Cutlery Drawer
- Glass care protection system for delicate crockery & glassware.
- Speed Perfect Plus
- ExtraDry
- 2x flip tines in Upper basket
- 2x flip tines in bottom basket
- Stainless steel tub
- Inbuilt Water softener
- Machine care
- AquaSensor, LoadSensor
- Child Lock – Control Panel
- AquaStop plus leak protection
- Detergent Automation

Programmes:

- **6 programmes:** Intensive 70°C, Auto 45-65°C, Eco 50°C, Express 65°C, Silence 50°C, Custom programme
- **5 special options:** ExtraDry, HalfLoad, SpeedPerfect Plus, Machine care, Remote Start

Technical information:

- Energy efficiency class: A++
- Energy consumption: 0.93 kWh
- Water consumption: 9.5 liters
- Noise level: 44 dB
- Appliance dimensions (HxWxD): 81.5cm x 59.8cm x 57.3cm



SMI46NS01E

Semi integrated,
13 place settings

Key Highlights:

- VarioSpeedPlus for 66% faster washing cycle
- Intensive 70°C for toughest oily & masala stained Indian utensils.
- 3 Stage Rackmatic Flexible Basket
- Silent wash with EcoSilence Drive
- DosageAssist
- Made In Germany

Design & Innovation:

- Glass care protection system for delicate crockery & glassware.
- Express 60°C Wash & dry in 60 mins
- Additional cutlery Drawer
- 2x flip tines in upper basket
- 4x flip tines in bottom basket
- Stainless steel tub
- Inbuilt Water softener
- Machine Care
- AquaSensor, LoadSensor
- Child lock – Control Panel
- AquaStop leak protection
- Detergent Automation

Programmes:

- **6 programmes:** Intensive 70°C, Auto 45-65°C, Eco 50°C, Express 60°C, Glass 40°C, Turbo speed 20 min
- **3 special options:** ExtraDry, VarioSpeed Plus, Machine care

Technical information:

- Energy efficiency class: A++
- Energy consumption: 0.93 kWh
- Water consumption: 6.7 liters
- Noise level: 46 dB
- Appliance dimensions (HxWxD): 81.5cm x 60cm x 57.3 cm

Technical Diagrams

All descriptions and technical diagrams are intended as a guide only. For additional technical information, full dimensional and installation details, please refer to the instruction and installation manuals supplied with the appliance. All measurements in mm.

SMI46NS01E

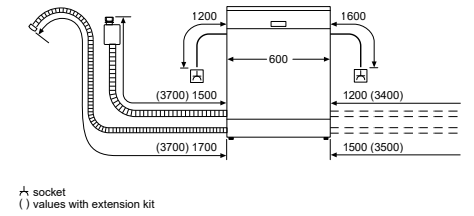
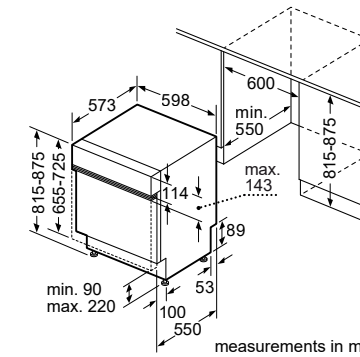

SMD6ZCX50E

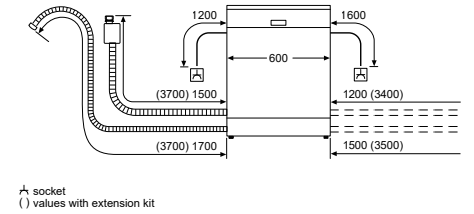
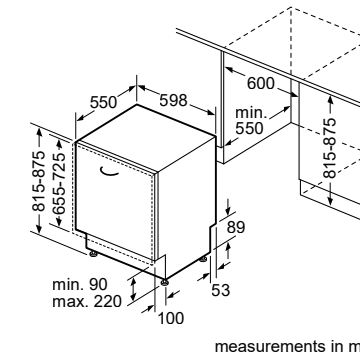

SMI4HCS48E

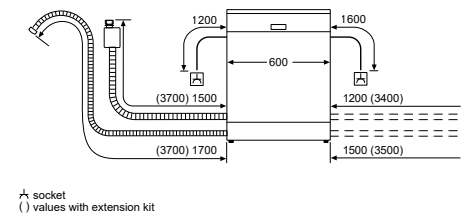
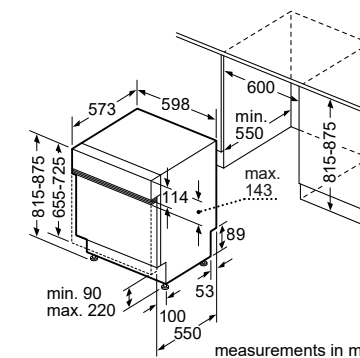

DosageAssist

The DosageAssist feature maximises the effectiveness of detergent tablets by dropping them into a specially designed tray that is targeted by water jets, resulting in a tablet that dissolves evenly under control ensuring optimal usage.



CutleryDrawer A cutlery tray for cutlery and small dishes.



Washing Machine



A smarter way to a perfect wash with 100% accurate detergent dosing every time.

Bosch washing machine with the i-DOS technology is the wash care expert for your clothes. Its automatic dosing system dispenses the right amount of liquid detergent and water for a perfect wash.



Picture is for representation purpose only.

Key Innovations

Specific features vary by model



i-DOS System: The i-DOS system makes washing your clothes a hassle-free and time-saving experience. It measures the load of the laundry in the machine and dispenses the exact amount of detergent and water required for a smooth wash.



SpeedPerfect™: Wash your clothes faster with SpeedPerfect, a high-performance program that efficiently cuts down the duration of the wash cycle by up to 65%



HygieneCare: A unique wash program that keeps the fabric hygienic by treating your clothes with a dry high temperature before washing them.

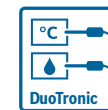

DuoTronic Technology: If you know how dry you want your clothes to be, a Bosch washing machine will ensure you get just that. The DuoTronic Technology is a clever dryer setting that detects the moisture level of your clothes, regulates the heat, sets the optimum temperature and perfect drying cycle, and dries your clothes. Additionally, it protects the colours of your clothes, ensures they stay soft and wrinkle-free too.





i-DOS* System:

To use i-DOS, simply fill the tank with up to 1.3 litres of liquid detergent. This smartly optimises the detergent usage and minimises the water and energy usage required during the rinsing process, and thus completes the wash cycles faster. You conserve up to 7,062* litres of water every year and up to 30% of liquid detergent in every wash cycle.



ActiveWater Plus*:

ActiveWater Plus optimises water usage with 256 load sensing levels, adjusting the water level automatically by sensing the laundry weight and fabric. Moreover, it uses hot water to thoroughly remove the detergent residue and bacteria formed inside the wash drum, giving you a hygienic & perfect washing experience.



*Feature may vary as per model.

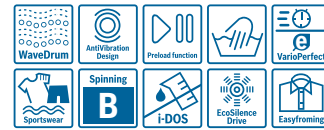

WAT28661IN
Serie | 6
Compact washer
9 kg, 1400 rpm

Key Highlights:

- i-DOS System automatically measures the precise amount of detergent and water needed for each load.
- EcoSilence Drive™ motor that's powerful and durable yet quieter than a normal conversation.
- SpeedPerfect™: high performance programme which reduces wash cycle duration by up to 65%
- AllergyPlus specially developed for the needs of allergy sufferers and sensitive skin.

Other Features:

- VarioPerfect™
- ActiveWater™ Plus
- AntiVibration™ Design
- SpeedPerfect™
- EcoProjection

Convenience & Safety:

- Large LED display screen to indicate: Programme status, Temperature and Spin Speed Selection, Remaining Time and 24 Hour End Time Delay, Load Recommendation and Consumption
- TouchControl buttons: Start/Reload, Temperature, ecoPerfect/speedPerfect, Rinse Plus, Spin Speed Reduction
- Buzzer at the end of the programme
- Multiple water protection with magnetic valve to minimise risk of leakage
- Child-proof lock
- Easy cleaning detergent drawer

Programmes:

- Cottons, Cotton Eco, Easy-Care, Delicates/Silk, Wool, Mix, Daily Wash, Rinse, Drum Clean, SuperQuick, Shirts, Sportswear, AllergyPlus, Automatic Soft
- Time delay to select end time of your wash (1 - 24 hours) and time remaining indicator
- Reload function to pause machine operation for adding in last minute laundry items

Technical Information:

- Dimensions (H x W x D): 84.8 x 59.8 x 63.2 cm

Optional accessories:

- WMZ20490 Platform with pull-out
- WMZ2200 Floor securing component
- WMZ2381 Extension for cold water inlet /Aquastop



WTB86202IN
Serie | 4
Compact condensation dryer,
8 kg

Key Highlights:

- DuoTronic
- SensitiveDrying System
- AllergyPlus

Other Features:

- Low Heat Drying
- AutoDry
- AntiVibration™ Design
- Fully electronic control dial for sensor drying, including timed and special programmes

Convenience & Safety:

- LED-Display for remaining time and 24 h end time delay, programme status indication, special functions
- Touch control buttons: start/pause, Low Heat, less ironing, programme length, Fine-tuning of drying aim, 24 h end time delay
- Buzzer to indicate the end of cycle
- Child-proof lock
- Drain Set
- Drum interior light: LED
- Glass door with frame silver-black grey
- Comfort lock
- Door hinge: right-hand
- Metal door closing hook

Programmes:

- Special programmes: allergy plus, Down wear, Mixed Load, shirts 15, Super
- Quick 40 minutes program, Sportswear, Wool Finish, Timed Program Cold
- Timed Program Warm

Technical Information:

- Dimensions (H x W x D): 84.2 cm x 59.8 cm x 59.9 cm
- Slide-under height of 85cm

Optional accessories:

- WMZ20600 Wool in basket - accessory
- WTZ11400 Stacking kit with pull-out shelf
- WTZ20410 Stacking kit



WVG30460IN
Serie | 6
All-in-one washer and dryer,
8/5.0 kg, 1500 rpm

Key Highlights:

- All-in-One Washer and Dryer
- EcoSilence Drive™ motor that's powerful and durable yet quieter than a normal conversation
- AllergyPlus: specially developed for the needs of allergy sufferers.
- HygieneCare: washing program with dry high temperature pretreatment for hygienic fabric care
- DuoTronic Technology: gently dries laundry to exactly the degree of dryness you want. Duo-Tronic Sensors monitors moisture levels and temperature to reach desired levels of dryness and to prevent overheating

Other Features:

- VarioPerfect™
- ActiveWater™Plus: resource gentle watermanagement
- AntiVibration™ Design
- Foam detection system
- Special Programmes - AllergyPlus, Daily Wash, HygieneCare
- Foam detection system to remove excessive foam
- Unbalanced load detection
- Drying: Intensive Dry, Gentle Dry, Wash and Dry 60
- Flow sensor for optimal wateruse
- Fully electronic control dial for all wash- and special programs
- VarioSoft drum system for shorter and more gentle washing

Convenience & Safety:

- Large LED-Display for programme status indication, temperature selection, max. spin speed, remaining time and 24 h end time delay and load recommendation
- TouchControl buttons: start/pause with reload function, Rinse plus, Start time delay, Spin speed selection, Temperature, drying, EcoPerfect/SpeedPerfect comfort and safety
- Buzzer at end of program
- Multiple water protection
- Child-proof lock

Programmes:

- Special programmes: allergy plus, down, Drum Clean, quick 15', HygieneCare, mixed load, Spin / Drain, single rinse, wool, delicates/silk
- Drying-option for special programmes washing
- Special programmes drying: Intensive dry, Low heat drying, Wash & Dry 60'

Technical Information:

- Dimensions (H x W x D): 84.8 x 59.8 x 59.0 cm
- Slide-under height of 85cm

Optional accessories:

- WMZ2420 Built-under cover



Technical Diagrams

All descriptions and technical diagrams are intended as a guide only. For additional technical information, full dimensional and installation details, please refer to the instruction and installation manuals supplied with the appliance. All measurements in mm.

WAT28661IN

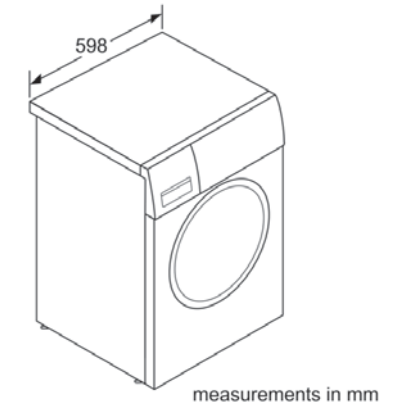
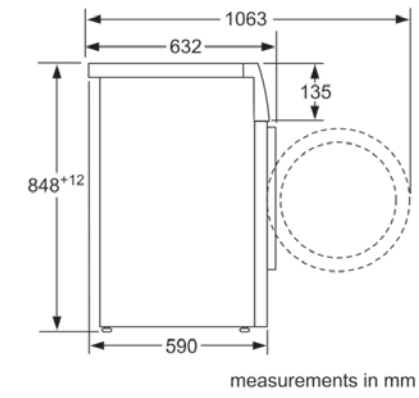

WVG30460IN

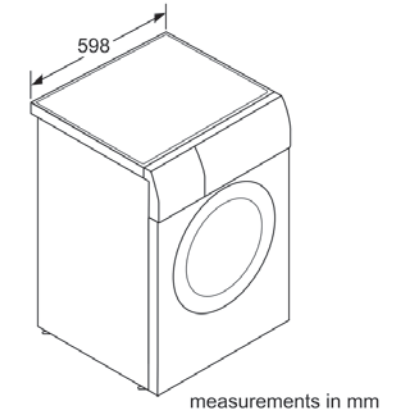
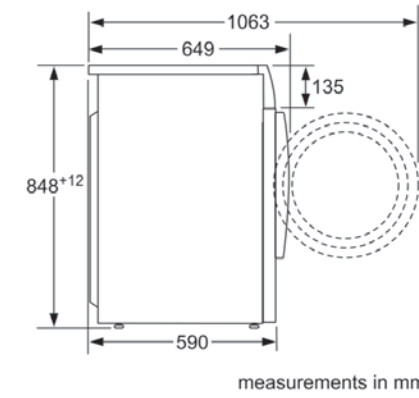

WTB86202IN

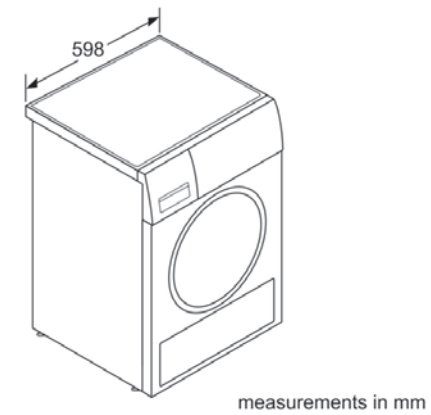

German efficiency even in our service.

Our appliances are built to meet your culinary needs and we are dedicated to deliver reliable and quality customer services.



Customer Care Service: Our Customer Call Center is available from Monday to Saturday 8 am to 8 pm at 1-800-26 6-1880. Closed on Sunday and Public holidays.



MyBosch Account: Bosch online store offers you the convenience to get your cleaning & care products, that will enhance the performance of your appliance. Create MyBosch account to get product related information.



Guarantee: We ensure the availability of spare parts for 10 years.



Warranty: Bosch home appliances are produced with maximum care, in high quality materials. We promise this in our 2-years manufacturer's warranty on Hob, Chimney, Microwave, Oven, Dishwasher, Refrigerator & Washing Machine.



Extended Warranty Plans: Added peace of mind with our extended warranty plans.



Repairs: Qualified specialists to handle repairs using original spare parts.



Website: Explore smart appliances, warranty packages, self-help videos, product brochures, tips and tricks for device care, book repair appointments and more on www.bosch-home.in

